



ROCHOLZ
LOGISTIK-ARBEITSPLÄTZE

WORKPLACES FOR LOGISTICS

Individually adaptable, ergonomic packing tables, cutting systems and assistance systems for intralogistics that provide users with targeted support for complex tasks and increase productivity.



SYSTEM FLEX, SYSTEM FLEX Light, SYSTEM 2000, SYSTEM BASIC, MODUL 5000, SYSTEM UP, Table frames, Table tops, Scale cut-outs, Roller track tables, Side guard, End stop, Locking plate, Transfer plate, Rocholz profile, Base frames, Extension frames, Storage shelves, Retracting shelf, Cover rail, Workplace lighting LED, Digital table scales, Holder for scale display unit, PC-holder, Thin client holder, Monitor support arms, Tablet holder, Installation panel, Shelf with retracting keyboard tray, Keyboard and mouse platform, Notebook shelf, Cable clips, Sockets, Cabel tray, Cabel duct, Shelf dividers, Stop edge, Partition plate, Stop brackets, Utensilo, Bottom shelf, Multifunctional rail, Fitting for tape holder, Bottel holder, Rubbish bag holder, Holder for pencils, cable ties etc., Drawer with extension, Lockable drawer, Extension poles, Workplace extension, Retracting shelf under the table, Dividers, Roll holder, Spindle set, Theme packages, Assistance and documentation systems, ProtecTable, Documen-Table, AssisTable, InspecTable, Lift tables and lifts, Ergonomic accessories, IT accessories, Accessories for perforated rear wall, Open fronted storage boxes, Tool holder set, Storage boxes, Spanner holder, Screwdriver holder, Drill and Allen key holder, Document tray, Cut resistant surface, Display panel holder with magnetic fastening, Cardboard storage racks, Table trolley, Storage box, Waste bin, Trolley for waste bin, Mobile suspension device, Transport systems, Magazine trolleys, Platform trolleys, Shelf trolleys, Cutting systems, Roll dispenser stands, Add-on cutter for packing table, Pneumatic cutting devices, Swivel castors, Winding attachment device, Roll dispenser with tear-off bar, Metre counter

SYSTEM FLEX, SYSTEM FLEX Light, SYSTEM 2000, SYSTEM BASIC, MODUL 5000, SYSTEM UP, Table frames, Table tops, Scale cut-outs, Roller track tables, Side guard, End stop, Locking plate, Transfer plate, Rocholz profile, Base frames, Extension frames, Storage shelves, Retracting shelf, Cover rail, Workplace lighting LED, Digital table scales, Holder for scale display unit, PC-holder, Thin client holder, Monitor support arms, Tablet holder, Installation panel, Shelf with retracting keyboard tray, Keyboard and mouse platform, Notebook shelf, Cable clips, Sockets, Cabel tray, Cabel duct, Shelf dividers, Stop edge, Partition plate, Stop brackets, Utensilo, Bottom shelf, Multifunctional rail, Fitting for tape holder, Bottel holder, Rubbish bag holder, Holder for pencils, cable ties etc., Drawer with extension, Lockable drawer, Extension poles, Workplace extension, Retracting shelf under the table, Dividers, Roll holder, Spindle set, Theme packages, Assistance and documentation systems, ProtecTable, Documen-Table, AssisTable, InspecTable, Lift tables and lifts, Ergonomic accessories, IT accessories, Accessories for perforated rear wall, Open fronted storage boxes, Tool holder set, Storage boxes, Spanner holder, Screwdriver holder, Drill and Allen key holder, Document tray, Cut resistant surface, Display panel holder with magnetic fastening, Cardboard storage racks, Table trolley, Storage box, Waste bin, Trolley for waste bin, Mobile suspension device, Transport systems, Magazine trolleys, Platform trolleys, Shelf trolleys, Cutting systems, Roll dispenser stands, Add-on cutter for packing table, Pneumatic cutting devices, Swivel castors, Winding attachment device, Roll dispenser with tear-off bar, Metre counter

SYSTEM FLEX, SYSTEM FLEX Light, SYSTEM 2000, SYSTEM BASIC, MODUL 5000, SYSTEM UP, Table frames, Table tops, Scale cut-outs, Roller track tables, Side guard, End stop, Locking plate, Transfer plate, Rocholz profile, Base frames, Extension frames, Storage shelves, Retracting shelf, Cover rail, Workplace lighting LED, Digital table scales, Holder for scale display unit, PC-holder, Thin client holder, Monitor support arms, Tablet holder, Installation panel, Shelf with retracting keyboard tray, Keyboard

Dear customers
and sales partners.
The new catalogue
is here!

Content



12 The right solution for every need: from single packing tables for low-level packers to highly flexible, efficient solutions for the most demanding processes.

06

OUR COMPANY

- 08** Ergonomics in the workplace
- 10** Product trainings

12

PACKING TABLES

- 14** Selection guide & Product features
- 16** SYSTEM FLEX
- 52** SYSTEM 2000
- 76** SYSTEM BASIC
- 84** MODUL 5000
- 96** SYSTEM UP
- 100** ESD accessories
- 102** Assistance & documentation systems
- 106** Lift tables and lifts
- 108** Ergonomic accessories
- 110** IT accessories
- 116** Accessories for Perforated rear wall
- 120** Other accessories

124

CUTTING SYSTEMS

- 128** Horizontal
- 130** Wall, table & vertical
- 131** Roll dispensers
- 132** Pneumatic cutting devices
- 134** Accessories



124 Our mobile or free-standing cutting systems can be integrated into the packing workplace, are suitable for various materials and easy to use.



Shop and office fittings and furnishing
Please request our catalogue on table frames, dispensers and contract manufacturing.



On our company premises in Velbert, Germany, our 80 employees work on a total area of 9440 sqm.

**QUALITY
MADE
IN GERMANY**

136
GTC

138
Imprint

MARC ROCHOLZ

MANAGING DIRECTOR



RALPH ROTH

MANAGING DIRECTOR



We are delighted to present you with our new catalogue, an expression of our commitment to ergonomic and efficient workplaces! With experience and expertise, coupled with creativity and innovation, we make solutions for you that sustainably future-proof your logistics.

In a brand-new design on the following pages, you will encounter both old acquaintances and exciting new additions to our product range, all of which are designed to provide you with the best possible support. Regardless of whether you are interested in a single table or in equipping an entire logistics centre, all our products ensure improved ergonomics, greater employee satisfaction and higher efficiency.

With SYSTEM FLEX (from p. 16), you gain a highly flexible, high-performance table system for logistics that can be adapted to any process and any user and can accommodate any required technology. SYSTEM FLEX Light (p. 25) is particularly suitable for start-ups looking for an uncomplicated solution for rapid growth on a smaller budget. Our digital assistance systems (from p. 102) offer special support that eliminates errors, counteracts the shortage of skilled labour, and allows people to work independently. Our lifting systems (from p. 106), facilitate a quick ergonomic upgrade, and we also create customised solutions for very individual requirements.

Together with our dedicated sales partners, we enable efficient and ergonomic processes in logistics – for you, too!

Have fun browsing and discovering!

ERGONOMICS

Ergonomics at the workplace

Since the 1980s, we as a company, have been working on ergonomics and the question of how to organise human work in a sustainably healthy way. The focus here is on how the work of the future will be shaped – both in the face of demographic change and in the course of digitalisation. Work should be human-centred and human-oriented: the workplace must therefore adapt to humans (and not vice versa).

With our own ergonomic workplace systems, we are right at the source of healthy working features and can help ourselves to the ergonomic tools of the trade. And that's what we do: our production and dispatch departments are equipped with our highly flexible ergonomic

packing and work tables, and in our offices we also use our work tables, which are certified as ergonomic.

Other modern companies have also long since recognised how much potential their employees have, and how valuable they are. Protecting and promoting their health is of the utmost importance in the company – not only to adapt to demographic change and prevent sickness-related absences, but also to increase productivity through employee satisfaction and to strengthen loyalty to the company.

The basis for ergonomic workplace design is the human being itself. Despite having the same „design“,

Accessories for ergonomics from page 104



INNOVATIONSPREIS ERGONOMIE 2022

Zertifiziert durch
IGR Institut für Gesundheit und Ergonomie
www.igr-ev.de



there are differences that you notice when you, for example, take over the packing workplace of a taller worker: it just doesn't fit. With body height as a starting point, there are many factors that yield the best results when individually adjusted.

So it quickly becomes clear that ergonomically valuable workstations must be as flexible and adaptable as possible so that each user can operate them adapted to their own individual ergonomics. Individually adaptable components are therefore a must-have: electric height adjustment, tool-free adjustable and inherently flexible holders, inclinable shelves that improve the reach position and workplace mats that safeguard the intervertebral discs and promote movement. Thanks to electric and pneumatic lifting tables etc., it is not necessary to bear heavy weights anymore, which makes work much easier, especially in logistics.

An organised and tidy workplace, where everything has its place and the work surface remains free for the actual work, is also important for ergonomically valuable work. Shelves with multiple uses and other well thought-out storage spaces are indispensable. Workplace lighting and the use of „small“ accessories such as bottle holders also make a huge contribution towards good health.



Solutions for a healthy workday

Industrial safety regulations prescribe basic safety measures to be observed when using work equipment.

We will help you to put these regulations into practice.



Ergonomic aids can be found from page 104 onwards. We are happy to advise you on optimal ergonomics, and are also happy to send you our ergonomics brochure, which provides more in-depth insights on this topic.

Thanks to our trained sales partners, you benefit from expert advice and custom solutions that optimally meet your individual requirements.

In our tried-and-tested training courses, our sales partners learn everything they need to know to provide you with the best possible advice, from analysing your needs, to planning and implementation. With the acquired knowledge you can solve the most complex requirements in no time.

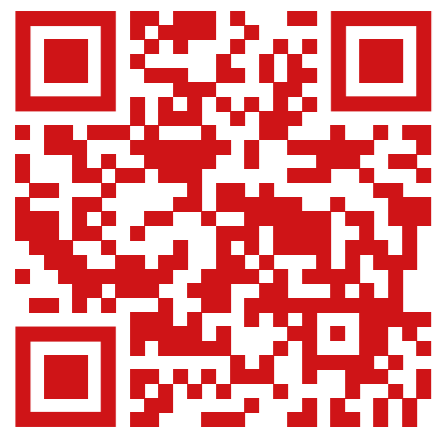
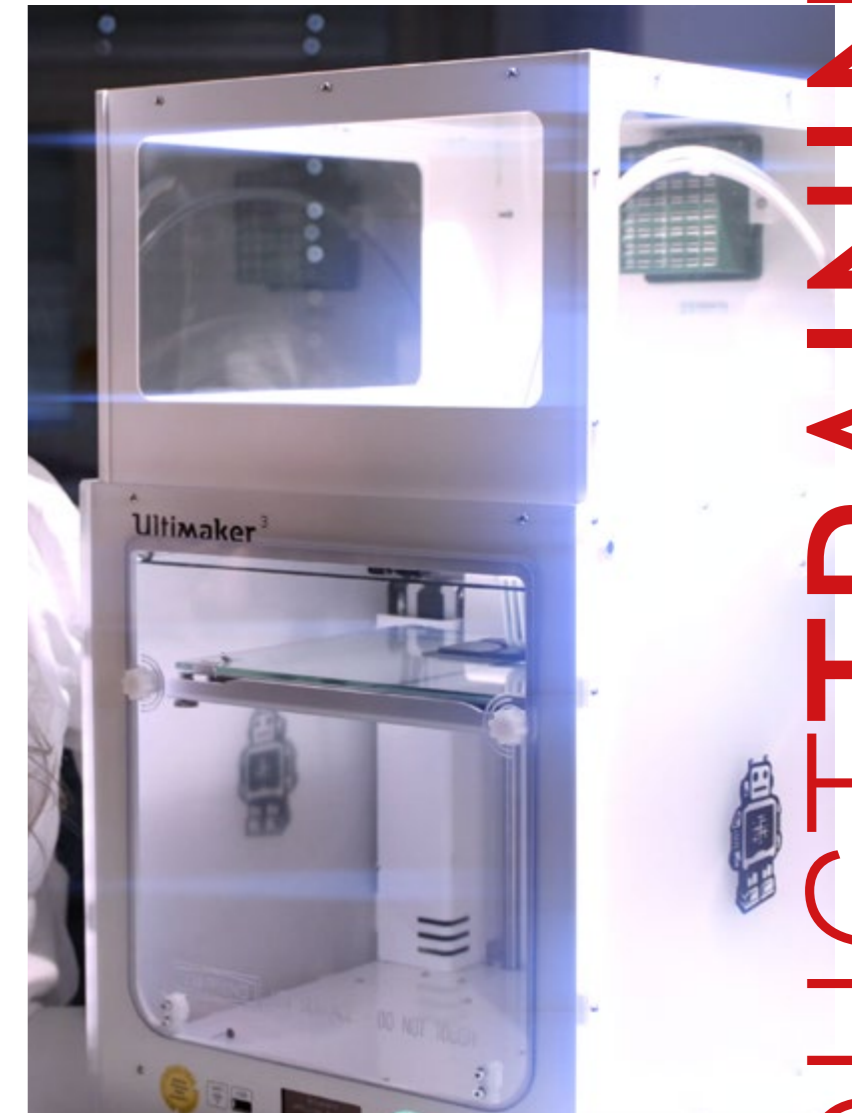

You can find the current training dates and course content as well as the registration forms on our website.

www.rocholz.de

01

Ergonomic packing
and workstation systems



Selection guide

	SYSTEM FLEX	SYSTEM FLEX LIGHT	SYSTEM 2000	SYSTEM BASIC	MODUL 5000
Flexibility is important to us, it should be easy to adapt the table to accommodate future processes.	●●●●	●●●●	●●●●	●●●●	●●●●
Ergonomics at the workplace are a key issue for us.	●●●●	●●●●	●●●●	●●●●	●●●●
The design and look of the table are crucial aspects for us.	●●●●	●●●●	●●●●	●●●●	●●●●
We attach great value to an extensive range of accessories with numerous shelves, PC solutions, etc.	●●●●	●●●●	●●●●	●●●●	●●●●
Our packing tables are used for shift work or several people share them at any one time.	●●●●	●●●●	●●●●	●●●●	●●●●
Our requirements are extremely complex. In some areas we will definitely require custom solutions.	●●●●	●●●●	●●●●	●●●●	●●●●
A packing table that just offers the main functions is all we need. The solution must be inexpensive.	●●●●	●●●●	●●●●	●●●●	●●●●
We want to make a quick decision. Do you have complete, pre-configured packing tables?	●●●●	●●●●	●●●●	●●●●	●●●●

Comparison chart

	SYSTEM FLEX	SYSTEM FLEX LIGHT	SYSTEM 2000	SYSTEM BASIC	MODUL 5000
Table width 1200	●		●		
Table width 1600	●	●	●	●	
Table width 2000	●		●	●	●
Table depth	800	800	800/920	800	880
Uprights for accessories, straight	●	●	●	●	
Uprights for ergonomically inclined	●				●
Variably positionable uprights	●				
Variably angled accessories	●	●			
Adjustable height	●		●		●
Height adjustment by crank			●		●
Height adjustment by motor	●	●	●		●
IGR certification „Ergonomic Product“	●				
Ergonomic accessories	●	●	●		●
Extensive range of accessories	●	●	●		●
Simple conversion /adaptation	●	●			
Special construction	●		●		●

SYSTEM FLEX

SYSTEM FLEX is perfect for everyone who wants unlimited flexibility and quickly adaptable ergonomics. This modular packing table with the clever SYSTEM FLEX fastening system enables lightning-fast adjustment to different processes and users.



Overview of special features:

- Sturdy and flexible thanks to our own in-house developed Rocholz steel profiles
- Grid perforation in the Rocholz profiles allows fast attachment of shelves, roll holders etc.
- The top section of the mounting profiles can be mounted upright or inclined at 20°. This improves the reach position to the shelves and accessories significantly.
- By detaching the mounting profiles from the table legs, add-on components can be moved horizontally and positioned at will.
- Extensive range of accessories

Light

SYSTEM FLEX Light allows you to use the advantages of a high-end pro solution at the price of an entry-level system.

With standard electric height adjustment and the option of using all SYSTEM FLEX accessories above the table, SYSTEM FLEX Light scores top points in terms of amortisation and succeeds in balancing high performance and cost-effectiveness.

1 SYSTEM FLEX complete packing station model 1

- SYSTEM FLEX basic table white aluminium (RAL 9006), accentuating colour ruby red (RAL 3003)
- 3 x Rocholz mounting profile with perforation H 1745 mm, long straight version
- 2 x shelf type A, W 1,000 x D 400 mm
- 2 x shelf type A, W 1,000 x D 300 mm
- 1 x stop edge, W 1,000 mm
- 8 x shelf dividers, open, black

with shelves and Rocholz mounting profiles with perforation for various accessories

Art. 73001500 W 2,000 x D 800 x H 690-960 mm, weight 115 kg



2 SYSTEM FLEX complete packing station model 2

like model 1 and additionally

- 1 x perforated back panel, W 1,000 x H 500 mm
- 2 x shelf type A, W 1,000 x D 400 mm
- 8 x shelf dividers, open, black
- 1 x single drawer, locked, W 527 x D 510 x H 200 mm
- 1 x bottle holder
- 1 x holder for adhesive tape dispenser for attaching to Rocholz profile with perforation

like model 1 with additional accessories

Art. 73001600 W 2,000 x D 800 x H 690-960 mm, weight 165 kg

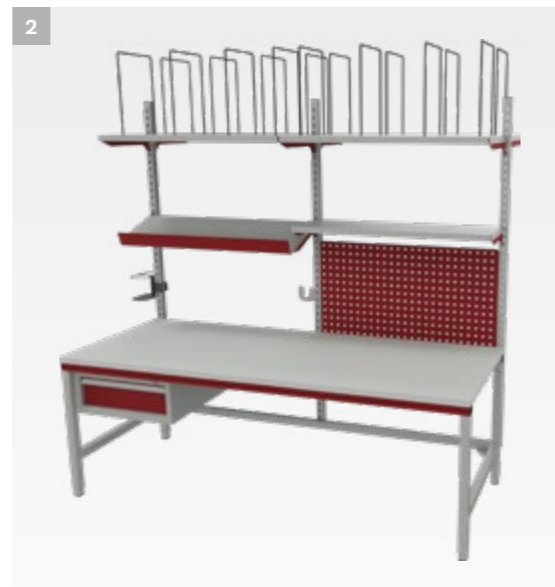

3 SYSTEM FLEX complete packing station model 3

- SYSTEM FLEX basic table with electric height adjustment, white aluminium (RAL 9006), accentuating colour ruby red (RAL 3003)
- 3 x Rocholz mounting profile with perforation, H 1,745 mm, long inclined version
- 1 x perforated back panel, W 1,000 x H 500 mm
- 1 x perforated back panel, W 1,000 x H 10 mm
- 2 x shelf type A, W 1,000 x D 400 mm
- 1 x shelf type A, W 1,000 x D 300 mm
- 2 x shelf type B, W 1,000 x D 300 mm
- 3 x stop edge, B 1,000 mm
- 16 x shelf dividers, open, black
- 1 x LED workplace lighting, W 661 x D 51 x H 54 mm, with dimming function, rotatable, 21 W, 903 LUX
- 1 x single drawer, locked, W 527 x D 510 x H 200 mm
- 1 x retracting shelf, W 1,000 x D 500 x H 140 mm
- 1 x Thin Client holder, W 300 x D 70-120 mm
- 1 x monitor folding arm, W 100 x D 455 x H 115 mm, incl. Novus Flexadapter
- 1 x keyboard and mouse platform with folding arm, W 640 x D 470 x H 50 mm
- 1 x bottle holder

with electric height adjustment

Art. 73001700 W 2,000 x D 800 x H 720-1,120 mm, weight 230 kg



4 SYSTEM FLEX complete packing station model 4

- SYSTEM FLEX basic table, white aluminium (RAL 9006)
- 1 x table top with scale cut-out, incl. mounting plate
- 3 x Rocholz mounting profile with perforation, H 1,745 mm, long straight version
- 3 x assembly set for inclined version
- 1 x perforated back panel, W 800 x H 100 mm
- 5 x shelf type A, W 800 x D 300 mm
- 2 x shelf type B, W 800 x D 300 mm
- 2 x cover rail
- 2 x cable duct for attachment to shelves, length 800 mm
- 4 x shelf dividers, open, black
- 1 x LED workplace lighting, W 661 x D 51 x H 54 mm, with dimming function, rotatable, 21 W, 903 LUX
- 1 x single drawer, locked, W 527 x D 510 x H 200 mm
- 1 x Thin Client holder, W 300 x D 70-120 mm
- 1 x monitor folding arm, W 100 x D 455 x H 200 mm, incl. Novus Flexadapter
- 2 x 4-socket outlet
- 1 x power supply cable, length 3 m

with scale cut-out and various accessories, accentuating colour gentian blue (RAL 5010)

Art. 73001800 W 1,600 x D 800 x H 690-930 mm, weight 200 kg

5 SYSTEM FLEX complete packing station model 5

- SYSTEM FLEX basic table, white aluminium (RAL 9006)
- 1 x table top with scale cut-out, incl. mounting plate
- 3 x Rocholz mounting profile with perforation, H 1,745 mm, long straight version
- 3 x assembly set for inclined version
- 3 x perforated back panel, W 800 x H 100 mm
- 5 x shelf type A, W 800 x D 300 mm
- 2 x shelf type B, W 800 x D 300 mm
- 2 x cover rail
- 2 x cable duct for attachment to shelves, length 800 mm
- 16 x shelf dividers, open, black
- 1 x LED workplace lighting, W 661 x D 51 x H 54 mm, with dimming function, rotatable, 21 W, 903 LUX
- 1 x single drawer, locked, W 527 x D 510 x H 200 mm
- 1 x thin client holder, W 300 x D 70-120 mm
- 1 x monitor folding arm, W 100 x D 455 x H 200 mm, incl. Novus Flexadapter
- 2 x 4-socket outlet
- 1 x power supply cable, length 3 m

with scale cut-out and various accessories, accentuating colour ruby red (RAL 3003)

Art. 73001900 W 1,600 x D 800 x H 660-930 mm, weight 200 kg





1 SYSTEM FLEX basic table with integrated lifting unit

tubular steel frame 40 x 40 mm, functional struts made of Rocholz profile with perforation in accentuating colour, infinitely height-adjustable via clamping screws from 750-960 mm, tabletop 30 mm thick, melamine resin-coated, surface light grey with 2 mm ABS edge, max. surface load of lifting platform 80 kg, stroke 350 mm, lifting speed 40 mm/sec (without load) and 30 mm/sec (with load), operation via foot switch, 230 V, accentuating colour ruby red (RAL 3003), max. surface load 300 kg (not on the lifting column)

useable area lifting platform W 800 x D 600 mm

Art. 73002200 W 2,000 x D 800 x H 750-960 mm, weight 112 kg



2 SYSTEM FLEX basic table electric for Cobot applications

aluminium lifting column with spindle drive, functional struts made of Rocholz profile with perforation in accentuating colour, lifting speed 12 mm/sec, with control panel and 4-fold memory storage as standard, table top 40 mm, accentuating colour ruby red (RAL 3003)

infinitely variable electric height adjustment from 730 - 1,130 mm

Art. 73002500 W 2,000 x D 800 x H 730-1,130 mm, weight 124 kg

3 SYSTEM FLEX mobile rechargeable

aluminium lifting column with spindle drive, functional struts made of Rocholz profile with perforation in accentuating colour, infinitely variable electric height adjustment from 720-1,120 mm, lifting speed 7.5 mm/sec, with control panel and 3-fold memory storage as standard, table top 30 mm thick, melamine resin-coated, surface light grey with 2 mm ABS edge, accentuating colour gentian blue (RAL 5010)

power supply with rechargeable battery (24 VDC, 6 Ah) incl. charging station for exchangeable battery pack

Art. 73601225 W 1,200 x D 800 x H 720-1,120 mm, weight 59.8 kg





1 SYSTEM FLEX basic table manual

tubular steel frame 40 x 40 mm, functional struts made of Rocholz profile in accentuating colour, height-adjustable from 690-960 mm, infinitely variable via clamping screws, table top 30 mm thick, melamine resin-coated, surface light grey with 2 mm ABS edge

max. surface load 300 kg

Art. 73000000	W 1,200 x D 800 x H 690-960 mm, weight 41 kg, ruby red
Art. 73000100	W 1,600 x D 800 x H 690-960 mm, weight 50.4 kg, ruby red
Art. 73000200	W 2,000 x D 800 x H 690-960 mm, weight 53.3 kg, ruby red
Art. 73000001	W 1,200 x D 800 x H 690-960 mm, weight 41 kg, gentian blue
Art. 73000101	W 1,600 x D 800 x H 690-960 mm, weight 50.4 kg, gentian blue
Art. 73000202	W 2,000 x D 800 x H 690-960 mm, weight 53.3 kg, gentian blue

2 SYSTEM FLEX basic table with electric height adjustment

aluminium lifting column with spindle drive, infinitely variable via electric motor, height-adjustable from 720-1,120 mm, tubular steel frame 40 x 40 mm, functional struts made of Rocholz profile in accentuating colour, table top 30 mm thick, melamine resin-coated, surface light grey with 2 mm ABS edge, max. surface load 300 kg

max. lifting speed 12 mm/sec.

Art. 73000600	W 1,200 x D 800 x H 720-1,120 mm, weight 59.8 kg, ruby red
Art. 73000700	W 1,600 x D 800 x H 720-1,120 mm, weight 68.8 kg, ruby red
Art. 73000800	W 2,000 x D 800 x H 720-1,120 mm, weight 78.3 kg, ruby red
Art. 73000601	W 1,200 x D 800 x H 720-1,120 mm, weight 59.8 kg, gentian blue
Art. 73000701	W 1,600 x D 800 x H 720-1,120 mm, weight 68.8 kg, gentian blue
Art. 73000801	W 2,000 x D 800 x H 720-1,120 mm, weight 78.3 kg, gentian blue

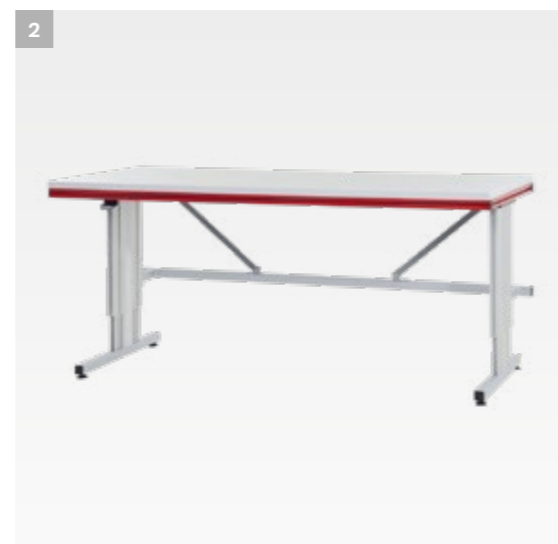

All electrically height-adjustable SYSTEM FLEX tables (except Light) are equipped as standard with our control panel with fourfold memory storage.

3 SYSTEM FLEX table frame manual

tubular steel frame 40 x 40 mm, functional struts made of Rocholz profile in accentuating colour, height-adjustable from 660-930 mm, max. surface load 300 kg

infinitely height-adjustable via clamping screws

Art. 73100000	W 1,200 x D 800 x H 660-930 mm, weight 23.5 kg, ruby red
Art. 73100900	W 1,600 x D 800 x H 660-930 mm, weight 27.3 kg, ruby red
Art. 73100202	W 2,000 x D 800 x H 660-930 mm, weight 29.5 kg, ruby red
Art. 73100001	W 1,200 x D 800 x H 660-930 mm, weight 23.5 kg, gentian blue
Art. 73100901	W 1,600 x D 800 x H 660-930 mm, weight 27.3 kg, gentian blue
Art. 73100201	W 2,000 x D 800 x H 660-930 mm, weight 29.5 kg, gentian blue

4 SYSTEM FLEX table frame with electric height adjustment

aluminium lifting column with spindle drive, infinitely variable via electric motor, height-adjustable from 690-1,090 mm, tubular steel frame 40 x 40 mm, functional struts made of Rocholz profile in accentuating colour, max. surface load 300 kg

max. lifting speed 12 mm/sec.

Art. 73100600	W 1,200 x D 800 x H 690-1,090 mm, weight 47.6 kg, ruby red
Art. 73100700	W 1,600 x D 800 x H 690-1,090 mm, weight 52.9 kg, ruby red
Art. 73100800	W 2,000 x D 800 x H 690-1,090 mm, weight 54.1 kg, ruby red
Art. 73100601	W 1,200 x D 800 x H 690-1,090 mm, weight 47.6 kg, gentian blue
Art. 73100701	W 1,600 x D 800 x H 690-1,090 mm, weight 52.9 kg, gentian blue
Art. 73100801	W 2,000 x D 800 x H 690-1,090 mm, weight 54.1 kg, gentian blue

1 SYSTEM FLEX table top

table top melamine resin-coated, surface light grey with 2 mm ABS edge, table top 30 mm thick

Art. 73200010	W 1,200 x D 800 x H 30 mm, weight 18 kg
Art. 73200110	W 1,600 x D 800 x H 30 mm, weight 24 kg
Art. 73200210	W 2,000 x D 800 x H 30 mm, weight 30 kg

ESD conductive table top 30 mm thick in accordance with IEC 61340-5-1, HPL-coated, surface light grey with 2 mm ABS edge, connection set consisting of push buttons, information sticker and 3 m connection cable

Art. 73200310	W 1,200 x D 800 x H 30 mm, weight 21.2 kg
Art. 73200410	W 1,600 x D 800 x H 30 mm, weight 27.1 kg
Art. 73200510	W 2,000 x D 800 x H 30 mm, weight 33.7 kg

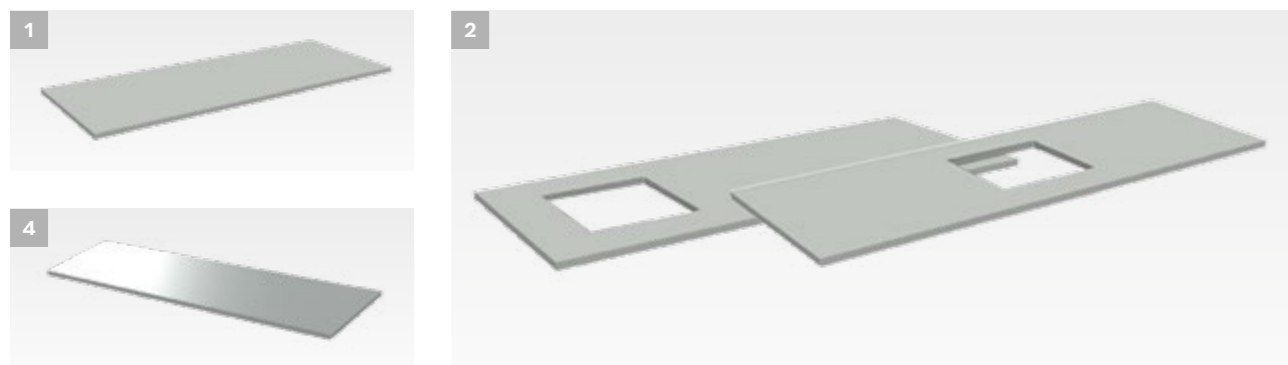

2 Table top with scale cut-out

table top 30 mm thick, melamine resin-coated, surface light grey with 2 mm ABS edge, scale cut-out W 516 x D 416 mm, cut-out position from the front 100 mm and from the side 200 mm, individual cut-outs in the table top and mounting plate on request, WITHOUT mounting plate and mounting kit for scale installation

Scale cut-out optionally on the left, right or in the centre

Art. 73200610	W 1,200 x D 800 x H 30 mm, weight 14 kg, scale cut-out left or right
Art. 73200700	W 1,600 x D 800 x H 30 mm, weight 20 kg, scale cut-out left or right
Art. 73200800	W 2,000 x D 800 x H 30 mm, weight 26 kg, scale cut-out left or right
Art. 73201200	W 1,200 x D 800 x H 30 mm, weight 14 kg, scale cut-out in centre
Art. 73201300	W 1,600 x D 800 x H 30 mm, weight 20 kg, scale cut-out in centre
Art. 73201400	W 2,000 x D 800 x H 30 mm, weight 26 kg, scale cut-out in centre

3 Mounting plate *(without image)*

for table tops with scale cut-out, a mounting plate must be ordered to integrate a scale; for scale height 105 mm

Art. 73203700	W 77 x D 715 x H 75 mm, weight 2.7 kg
---------------	---------------------------------------

4 Table top with stainless steel cover

table top 30 mm thick, with 2 mm ABS e

Art. 73202100	W 1,200 x D 800 x H 30 mm, weight 31 kg
Art. 73202200	W 1,600 x D 800 x H 30 mm, weight 41 kg
Art. 73202300	W 2,000 x D 800 x H 30 mm, weight 53 kg

1 SYSTEM FLEX Light basic table set

SYSTEM FLEX Light allows you to use the advantages of a high-end pro-version at the price of an entry-level system. Our light version with standard electric height adjustment succeeds in balancing high performance and cost-effectiveness, setting new standards for packing tables. Modular SYSTEM FLEX accessories (800 mm) such as shelves, holders and other ergonomically adjustable add-ons can be mounted above the packing table, where they guarantee flexible functionality and expand your efficiency expertly.



1 SYSTEM FLEX Light basic table set

basic table set with electric height adjustment, incl. 3 Rocholz mounting profiles with perforation for attaching all accessories from the SYSTEM FLEX range in system width 800 mm, table top 19 mm thick, incl. two perforated back panels which function as crush protection and can also be used to store the hook range, for example, accentuating colour RAL 9006/3003, max. surface load 120 kg **max. lifting speed 31 mm/sec**

Art. 73805200	W 1,650 x D 800 x H 720-1,220 mm, weight 92.5 kg
---------------	--

2 SYSTEM FLEX Light drawer

in RAL 9006 white aluminium, max. surface load 10 kg **useable space W 600 x D 250 x H 120 mm**

Art. 73805600	W 650 x D 265 x H 125 mm, weight 10 kg
---------------	--



1 SYSTEM FLEX roller track table

tubular steel frame 40 x 40 mm, functional struts made of Rochoolz profile, height-adjustable from 690-960 mm, infinitely variable via clamping screws, roller width 600 mm

max. surface load 120 kg

Art. 73400700	W 1,200 x D 680 x H 690-960 mm, weight 38 kg
Art. 73400800	W 1,730 x D 680 x H 690-960 mm, weight 47 kg
Art. 73400900	W 2,100 x D 680 x H 690-960 mm, weight 54 kg

2 Side guard for SYSTEM FLEX roller track table

surface RAL 9006 aluminium white

Limiters for safely guiding packages and parcels on the roller track

Art. 73408000	W 1,195 x D 40 x H 40 mm, weight 3.4 kg
Art. 73408100	W 1,725 x D 40 x H 40 mm, weight 4.8 kg
Art. 73408200	W 2,100 x D 40 x H 40 mm, weight 5.8 kg

3 End stop for SYSTEM FLEX roller track tables

height 100 mm above the rollers

only in the area of the roller tracks

Art. 73409100	W 600 x D 10 x H 100 mm, weight 3.3 kg
---------------	--



4 Locking plate

simply attach and stop the flow, for roller track tables with a roller track width of 600 mm + 75 mm division

galvanised surface

Art. 203544	W 600 x D 125 x H 62.5 mm, weight 1.4 kg
-------------	--

5 Base frame

infinitely variable height adjustment via clamping screws from 670-940 mm, foot plate for floor mounting

for mounting the transfer plate

Art. 73600870	W 685 x D 112 x H 670-940 mm, weight 8.5 kg
---------------	---

6 Transfer plate

from table to roller track table with a width of 600 mm, 265 mm min. distance between table and roller track table

telescope extension from 265-395 mm (130 mm extendable)

Art. 73600230	W 620 x D 265-395 x H 104 mm, weight 5.8 kg
---------------	---



1 Rocholz mounting profile with perforation, continuous

with 2 functional grooves and 2 rows of system perforations, in RAL 9006 white aluminium
for straight mounting

- 1.1 Art. 73309200 W 40 x D 40 x H 1,033 mm (short), Height above the table 520 mm, weight 2 kg
- 1.2 Art. 73300250 W 40 x D 40 x H 1,995 mm (long), Height above the table 1,210 mm, weight 5 kg

2 Rocholz mounting profile with perforation, 2 parts

with 2 functional grooves and 2 rows of system perforations, in RAL 9006 white aluminium
2 parts for straight or inclined installation

- 2.1 Art. 73308000 W 40 x D 40 x H 1,745 mm (2 parts, straight), Height above the table 1,745 mm, weight 5 kg
- 2.2 Art. 73308100 Assembly set for inclined version, weight 0.1 kg

3 Rocholz mounting profile with perforation, long, Heavy Duty

particularly sturdy design for heavy loads with 2 functional grooves and 2 rows of system perforations, colour RAL 9006 white aluminium
for straight installation

- Art. 73308010 W 80 x D 40 x H 1,725 mm (long), Height above the table 1,207 mm, weight 12 kg



4 Base frame for add-on elements

Rocholz mounting profiles with perforation with 2 functional grooves and 2 rows of system perforations, excl. assembly set for inclined installation

straight 2 parts

- Art. 73700000 W 837.5 x D 750 x H 1,974 mm, mounting width 800 mm, weight 19.3 kg
- Art. 73700100 W 1,037.5 x D 750 x H 1,974 mm, mounting width 1,000 mm, weight 19.8 kg
- Art. 73308100 W 40 x D 100 x H 10 mm (Assembly set for inclined installation), weight 0.1 kg

5 Extension frame for add-on elements

Rocholz mounting profiles with perforation with 2 functional grooves and 2 system hole perforations

straight 2 parts

- Art. 73700400 W 787.5 mm x D 750 x H 1,974 mm, mounting width 800 mm, weight 10.2 kg
- Art. 73700500 W 987.5 x D 750 x H 1,974 mm, mounting width 1,000 mm, weight 10.7 kg

6 Base frame for add-on elements

Rocholz mounting profiles with perforation with 2 functional grooves and 2 rows of system perforations

straight continuous

- Art. 73700200 W 837.5 x D 750 x H 2,046 mm, mounting width 800 mm, weight 19.5 kg
- Art. 73700300 W 1,037.5 x D 750 x H 2,046 mm, mounting width 1,000 mm, weight 20 kg

7 Extension frame for add-on elements

Rocholz mounting profiles with perforation with 2 functional grooves and 2 rows of system perforations

straight continuous

- Art. 73700600 W 787.5 x D 750 x H 2,048 mm, mounting width 800 mm, weight 10.4 kg
- Art. 73700700 W 987.5 x D 750 x H 2,048 mm, mounting width 1,000 mm, weight 10.9 kg



ATTENTION! If the shelves are also mounted to the rear, floor mounting is required!

1 Shelves

for hooking into the system perforations in the Rocholz mounting profiles with perforation, for inclining at -20°, 0° and +20°. The shelves are prepared for the use of shelf dividers and stop brackets, delivery includes carrier arms, various widths and depths in two heights allow for countless combinations, max. surface load 25 kg

A Shelves type A

Art. 73306900	W 800 x D 200 mm, weight 2.5 kg, ruby red
Art. 73307000	W 800 x D 300 mm, weight 3.4 kg, ruby red
Art. 73307100	W 800 x D 400 mm, weight 4.8 kg, ruby red
Art. 73307200	W 1,000 x D 200 mm, weight 2.9 kg, ruby red
Art. 73307300	W 1,000 x D 300 mm, weight 4 kg, ruby red
Art. 73307400	W 1,000 x D 400 mm, weight 5 kg, ruby red
Art. 73313000	W 1,600 x D 300 mm, weight 3.2 kg, ruby red
Art. 73306901	W 800 x D 200 mm, weight 2.5 kg, gentian blue
Art. 73307001	W 800 x D 300 mm, weight 3.4 kg, gentian blue
Art. 73307101	W 800 x D 400 mm, weight 4.8 kg, gentian blue
Art. 73307201	W 1,000 x D 200 mm, weight 2.9 kg, gentian blue
Art. 73307301	W 1,000 x D 300 mm, weight 4 kg, gentian blue
Art. 73307401	W 1,000 x D 400 mm, weight 5 kg, gentian blue
Art. 73313001	W 1,600 x D 300 mm, weight 3.2 kg, gentian blue

B Shelves type B

Art. 73307500	W 800 x D 300 mm, weight 3.8 kg, ruby red
Art. 73307530	W 800 x D 400 mm, weight 5.8 kg, ruby red
Art. 73307600	W 1,000 x D 300 mm, weight 4.5 kg, ruby red
Art. 73307630	W 1,000 x D 400 mm, weight 6.8 kg, ruby red
Art. 73307501	W 800 x D 300 mm, weight 3.8 kg, gentian blue
Art. 73307531	W 800 x D 400 mm, weight 5.8 kg, gentian blue
Art. 73307601	W 1,000 x D 300 mm, weight 4.5 kg, gentian blue
Art. 73307631	W 1,000 x D 400 mm, weight 6.8 kg, gentian blue

C Shelves type C for Heavy Duty Rocholz mounting profiles with perforation

Art. 73306500	W 800 x D 200 mm, weight 2.6 kg, ruby red
Art. 73306800	W 800 x D 300 mm, weight 3.3 kg, ruby red
Art. 73307900	W 800 x D 400 mm, weight 4.5 kg, ruby red
Art. 73306700	W 1,000 x D 200 mm, weight 3.1 kg, ruby red
Art. 73307800	W 1,000 x D 300 mm, weight 4 kg, ruby red
Art. 73309100	W 1,000 x D 400 mm, weight 5.5 kg, ruby red
Art. 73306501	W 800 x D 200 mm, weight 2.6 kg, gentian blue
Art. 73306801	W 800 x D 300 mm, weight 3.3 kg, gentian blue
Art. 73307901	W 800 x D 400 mm, weight 4.5 kg, gentian blue
Art. 73306701	W 1,000 x D 200 mm, weight 3.1 kg, gentian blue
Art. 73307801	W 1,000 x D 300 mm, weight 4 kg, gentian blue
Art. 73309101	W 1,000 x D 400 mm, weight 5.5 kg, gentian blue

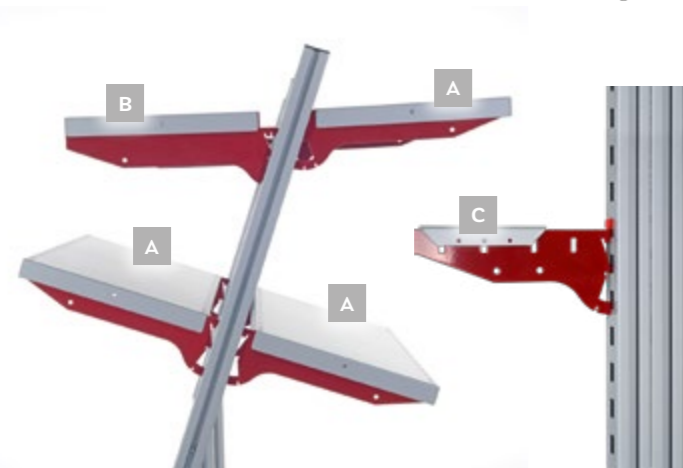

Please note for two-sided shelving:

For shelves that are at right angles to the Rocholz mounting profile with perforation, please order two type A shelves. Otherwise, type A and type B must be combined as shown in the image.

2 Reinforcement strut for shelves

support struts are screwed into the system groove of the Rocholz mounting profiles with perforation and attached to the shelf carrier arms

1 sales unit = 2 pcs.

Art. 73314400

W 350 x D 250 x H 11 mm, weight 0.5 kg

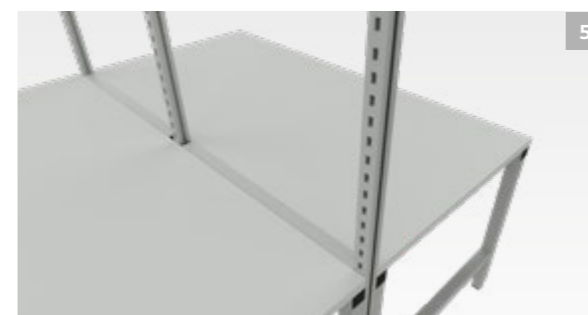
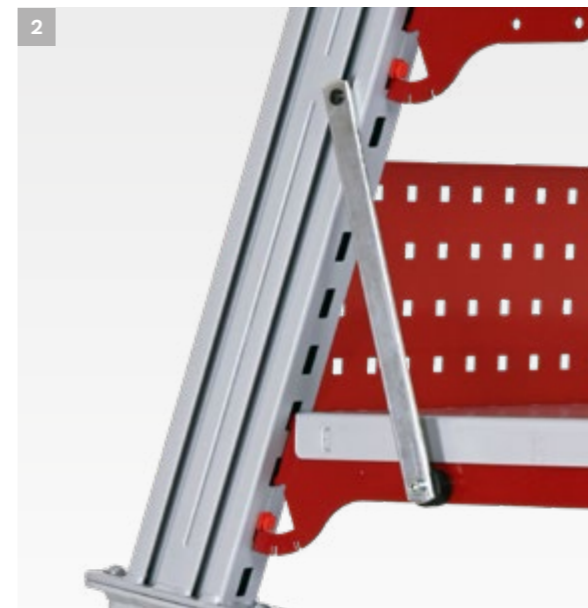

3 Lifting protection

for fastening in the system perforation of the Rocholz mounting profiles with perforation, red plastic, 1 sales unit = 10 pcs.

Lifting protection for carrier arms

Art. 73314000 weight 0.01 kg

4 Cover rail

for mounting between the Rocholz mounting profiles with perforation when combining front and rear shelves

Art. 73312000* W 736 x D 73 x H 30mm, weight 0.65 kg

Art. 73312100** W 936 x D 73 x H 30mm, weight 1.4 kg

* for mounting width 800 mm ** for mounting width 1,000 mm

5 Cover rail for double workplaces

for mounting between the Rocholz mounting profiles with perforation

Art. 73600050 W 800 x D 40 mm, weight 1.2 kg

Art. 73312900 W 1,000 x D 40 mm, weight 1.5 kg



Watch video

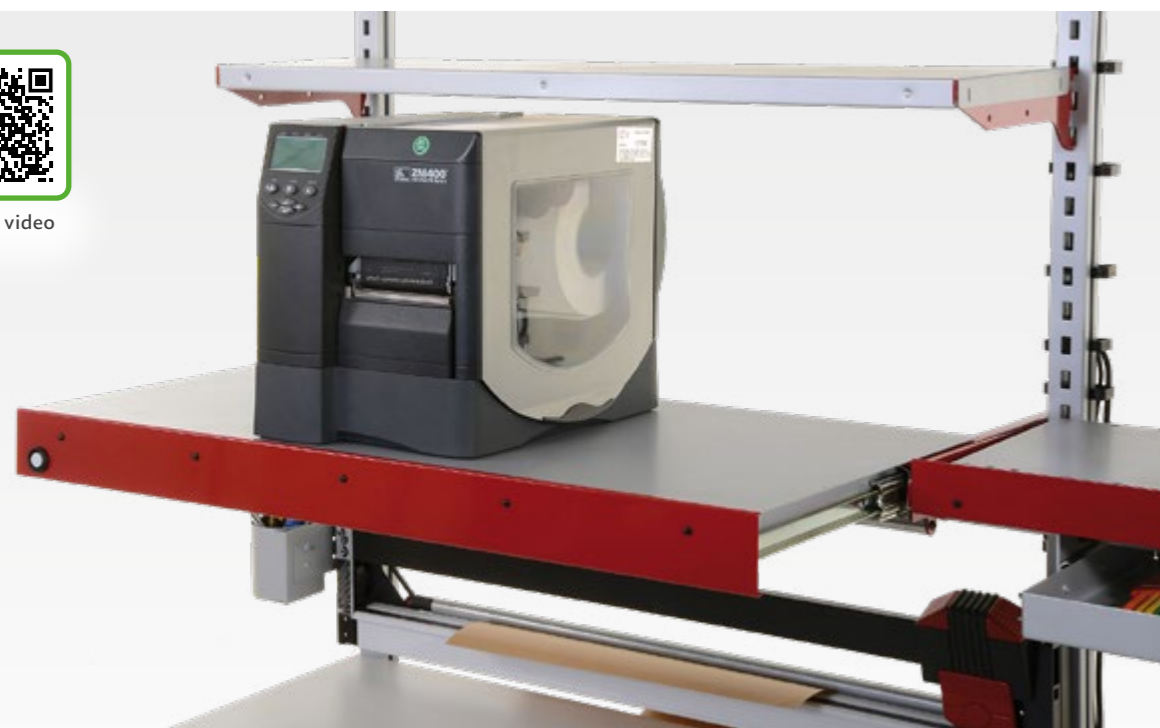

1

1 Retracting shelf for printers

for screwing into the system grooves in the Rocholz mounting profiles with perforation, adjustable height in system perforations, useable area W 720 x D 500 mm, max. surface load 40 kg

100% extension for easy roll change

Art. 73303600	W 800 x D 500 x H 140 mm, weight 10.9 kg, ruby red
Art. 73303702	W 1,000 x D 500 x H 140 mm, weight 13 kg, ruby red
Art. 73303601	W 800 x D 500 x H 140 mm, weight 10.9 kg, gentian blue
Art. 73303701	W 1,000 x D 500 x H 140 mm, weight 13 kg, gentian blue

2 Retracting shelf for Heavy Duty Rocholz mounting profiles with perforation for printers

for screwing into the system grooves in the Heavy Duty Rocholz mounting profiles with perforation, adjustable height in system perforations, useable area W 720 x D 500 mm, max. surface load 40 kg

100% extension for easy roll change

Art. 73304100	W 800 x D 500 x H 140 mm, weight 12.9 kg, ruby red
Art. 73304200	W 1,000 x D 500 x H 140 mm, weight 14.5 kg, ruby red
Art. 73304101	W 800 x D 500 x H 140 mm, weight 12.9 kg, gentian blue
Art. 73304201	W 1,000 x D 500 x H 140 mm, weight 14.5 kg, gentian blue



2

PACKING TABLE CONFIGURATOR

Plan your packing table online now



The packing table configurator supports you in your planning. With the new tool, you can put together your desired packing table configuration with just a few mouse clicks; either by yourself or together with your sales partner.

No software is required – simply open the configurator on our website from your PC, smartphone or tablet and you can configure a table right away and send us an enquiry.

Please feel free to contact us.

✉ vertrieb@rocholz.de

☎ +49 2053 819-0

ALL ADVANTAGES AT A GLANCE

- ✓ online tool – no software required
- ✓ convenient and easy configuration
- ✓ configure a table system according to your own individual requirements
- ✓ construction as a rotatable 3-D image from different perspectives
- ✓ send us an enquiry directly from the configurator

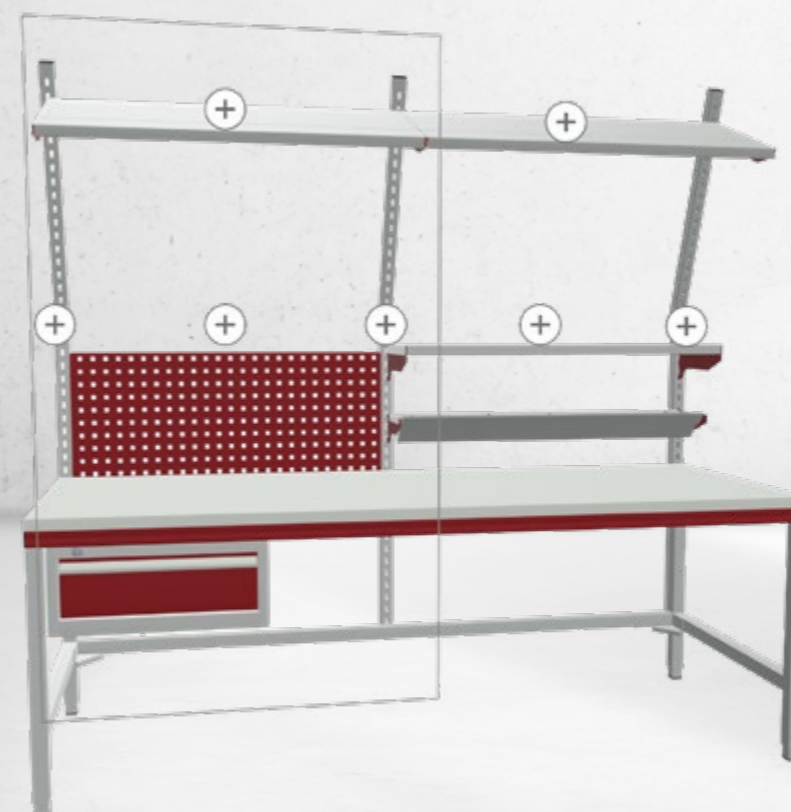
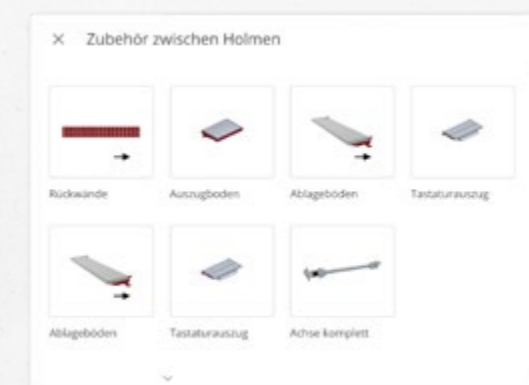

www.rocholz.de/en/service/packing-table-configurator



1 Workplace lighting LED

sturdy aluminium casing, for mounting under the shelves, 4,000 K, 0.15 A, protection class IP30, incl. connection cable

can be adjusted to lighting requirements with dimming function

Art. 73315710 W 661 x D 51 x H 54 mm, 21 W, 2.158 lm, weight 1.5 kg
 Art. 73315610 W 976 x D 51 x H 54 mm, 32 W, 3.368 lm, weight 1.8 kg

2 Workplace lighting Slim LED

for mounting on SYSTEM FLEX shelves (exception: one single shelf with system width 800 mm), 4,000 K, incl. external power supply unit

Art. 73601239 W 889 x D 32 x H 26,5 mm, 26,5 W, 2.500 lm, weight 0.34 kg

3 Supplementary workplace lighting LED

rotatable, for mounting in the system groove of the Rocholz mounting profile with perforation, incl. 4 m connection cable with shockproof plug, 4,000 K, protection class IP30

can be adjusted to lighting requirements with dimming function

Art. 73315810 W 465 x D 51 x H 65 mm, 13 W, 1.331 lm, weight 1.3 kg



IT accessories
from page 110



4 Digital table scale

evaluation unit made of ABS plastic, impact-resistant, protection class IP52, LCD display 30 mm, short-stroke keys, gross or net weight, tare correction; 2 m measuring cable with plug connection; 230 V power connection via external plug-in power supply unit, 1.8 m cable; internal rechargeable battery; weighing platform powder-coated, platform made of stainless steel, W 500 x D 400 mm, 1 strain gauge load cell made of anodised aluminium alloy, protection class IP66

weighing range up to 60 kg in 20 g increments

Art. 897052 W 500 x D 400 x H 82 mm, weight 13 kg



5 Digital table scale, legal for trade, IT connecti

evaluation unit made of stainless steel, protection class IP67, LCD display 25 mm, 10 freely designable printouts, 1 serial interface RS232 incl. approx. 2.4 m interface cable; scale division: up to 30 kg in 10 g, from 30 kg in 20 g; weighing range up to 60 kg; 2 m measuring cable (fixed connection); integrated 230 V power supply unit; powder-coated weighing platform, stainless steel platform, W 500 x D 400 mm, 1 strain gauge load cell made of anodised aluminium alloy, protection class IP66

Gross, net or tare weight, tare correction

Art. 897062 W 500 x D 400 x H 82 mm, weight 17.4 kg



6 Holder for scale display unit

for flexible attachment of a scale display unit with the supplied adapter in the system grooves of the Rocholz mounting profile with perforation, in RAL 9006 white aluminium, data cable must be at least be 2 metres long

max. load capacity 15 kg

Art. 73310700 W 117 x D 325 x H 135 mm, weight 2.9 kg

PROTECTABLE

✓ Efficient and ergonomic air cushion machine integration with storage silo

✓ Suitable for all standard air cushion machines (max. surface load 30 kg)



Watch video

ProtecTable is our SYSTEM FLEX add-on for integrating an automatic air cushion machine into your logistics workplace. The electric lift elevates the machine to its work position next to the storage silo and lowers it back to work table height for easy roll material changes. A silo with a storage net and mounting brackets for mounting to SYSTEM FLEX shelves collects the finished air cushions. The air cushions are stored in the silo for easy access through an opening in the net, allowing for

direct processing at the workplace. The lift is operated via a hand switch and the cables are organised and protected at the side of the table by an energy chain. In combination with your air cushion machine, this system makes for simple and safe packaging processes. The optionally available installation panel with a 4-socket outlet can be installed between the packing table's Rocholz mounting profiles and can also hold the air cushion machine's control unit, if desired.



- Lift-adjusting range approx. 1,025-2,325 mm (1,300 mm stroke)
- Dimensions platform W 330 x D 402 x H 221 mm
- Dimensions net and brackets for silo W 758 x D 671 x H 759 mm
- Mountable to 800 mm wide shelves with a total depth of 600 mm

1 ProtecTable – Lift

electric lift for e.g. air cushion machine, max. load capacity 30 kg when using the platform, assembly material is not included, weight 7 kg

incl. control unit and 220 V power supply cable 2.3 m

Art. 73316401

2 ProtecTable – Platform

platform for air cushion machine, weight 7 kg

incl. energy chain for guiding the cables and assembly set for lift and platform

Art. 73316402

3 ProtecTable – Silo

Storage net with mounting brackets for e.g. air cushions, weight 7.5 kg

net colour grey

Art. 73316201

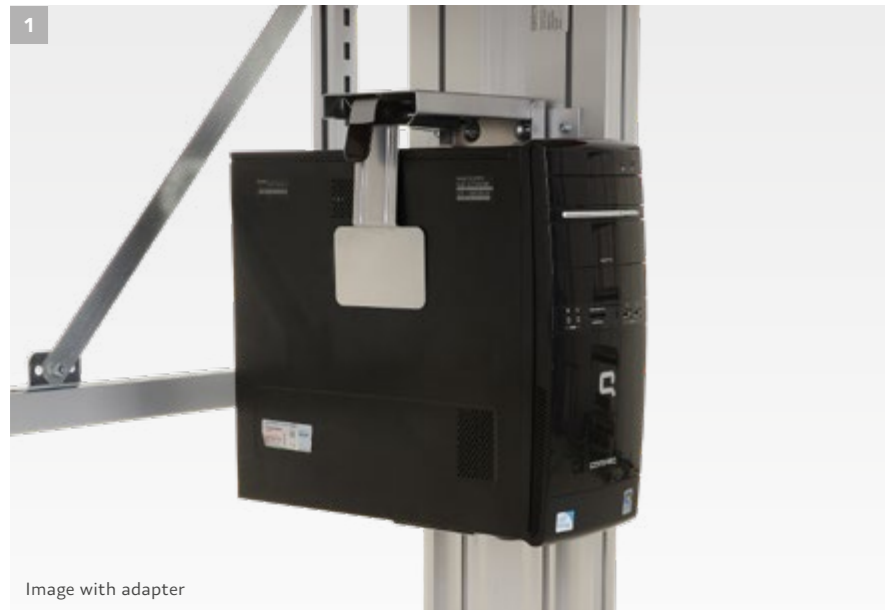

Image with adapter

1 PC holder

for mounting under the table, incl. fastening screws and drilling template
adjustable: interior height 307 - 531 mm, interior width 78 - 220 mm

Art. 228100 W 100-242 x D 150 x H 320-545 mm, weight 3 kg
 Art. 73316700 Adapter for mounting on the feet of the electric SYSTEM FLEX tables, weight 0.2 kg

2 Mini PC holder

for mounting under the table, incl. fastening screws and drilling template
adjustable: interior height 205 - 360 mm, interior width 50 - 100 mm

Art. 228110 W 160 x D 115 x H 240-395 mm, weight 2 kg

3 Mini PC holder for Rocholz profiles

for screwing into the system grooves of the Rocholz profiles with perforation
infinitely height-adjustable

Art. 73308300 W 300 x H 70-120 mm, weight 2 kg



Image on SYSTEM 2000

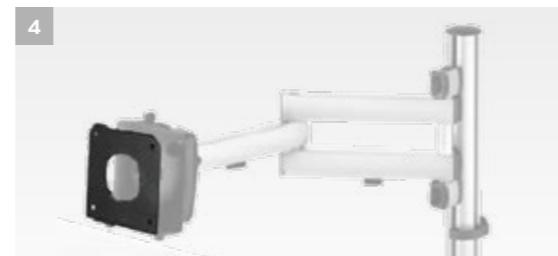

4 Thin client holder for monitor folding arm

for attaching between monitor folding arm and monitor, the holder can be continuously adjusted to the width of the thin client, max. load capacity 7.5 kg
suitable for VESA 100 x 100 mm

Art. 509211 W 35-53 mm, weight 0.9 kg

5 Adapter for monitor folding arms

for attaching monitor folding arms to inclined Rocholz mounting profiles with perforation
for positioning as required in the system grooves

Art. 73313600 weight 0.4 kg



6 Monitor folding arm

for flexible attachment of a monitor in the system grooves of Rocholz profiles with perforation, support column (509001, 509002, 509006), profile rail (509005) or upright adapter (509003), incl. cable holder

VESA 75/100 quick-release attachment

- 6.1 Art. 509203 W 100 x D 450 x H 120 mm, weight 2 kg, max. load capacity 10 kg
- 6.2 Art. 509204 W 100 x D 505 x H 200 mm, weight 2.1 kg, max. load capacity 15 kg
- 6.3 Art. 509207 W 100 x D 456-704 x H 200 mm, weight 2.5 kg, max. load capacity 8 kg
- 6.4 Art. 509209 W 100 x D 700 x H 200 mm, weight 2.5 kg, max. load capacity 10 kg

7 Tablet holder

for attaching to monitor folding arms (support arm not included), VESA 75/100 quick-release attachment, clamping range 160-300 mm
for tablets from 7" to 10"

Art. 509214 weight 0.5 kg

8 Double monitor holder

simple solution for monitor folding arms, VESA 75/100 quick-release attachment, suitable for monitor widths of 405-695 mm each and max. 6.4 kg (equals monitors up to approx. 30"), monitor holder has a fixed concave alignment of 7.5° on each side
Please observe the maximum total load capacity of the combined monitor folding arm!

Art. 509217 W 775 mm, weight 2.4 kg

9 Double monitor holder with gas pressure spring

2-part monitor support arm with traverse and gas pressure spring for double monitor mounting (without fastening), VESA 75/100 quick-release attachment, for 2 monitors up to max. 7 kg, for mounting to Rocholz profile with perforation (509250) or on the table (509251)

height-adjustable 180 - 480 mm

Art. 509249 weight 5.1 kg

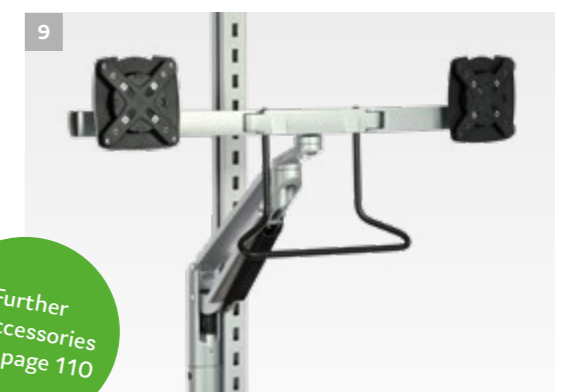
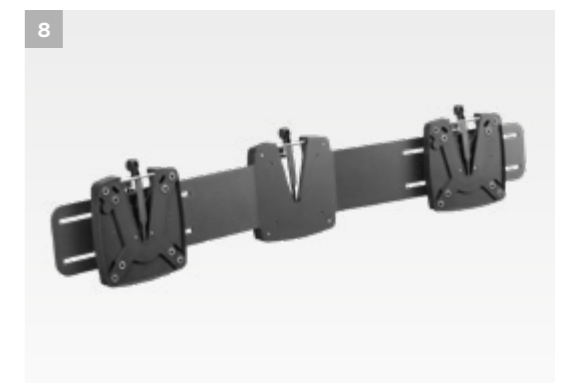
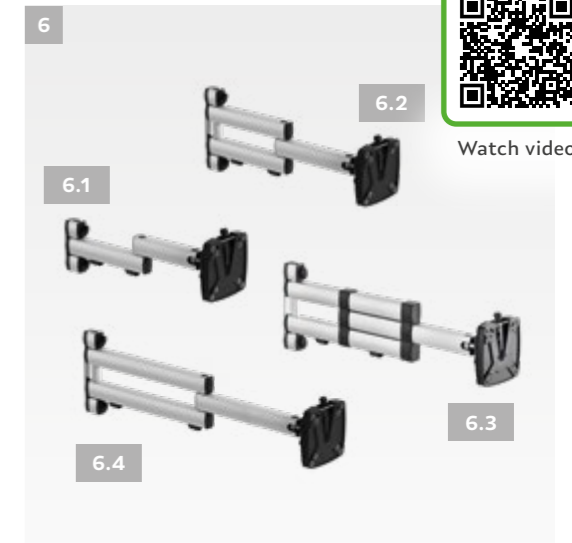

Further IT accessories from page 110



10 Universal shelf with double folding arm

can be mounted flexibly in height using the enclosed adapter in the system groove of the Rocholz mounting profiles with perforation, max. surface load 15 kg
swivelling range 325 mm + 200 mm

Art. 73311100 W 304 x D 500 mm,
 shelf W 300 x D 496 mm, weight 6.5 kg

11 Notebook tray with folding arm

for flexible mounting in the system grooves of Rocholz mounting profiles with perforation, support column (509001, 509002, 509006), profile rail (509005) or upright adapter (509003), cable opening in the platform, reach 589 mm
max. surface load 10 kg

Art. 509213 W 404 x D 589 x H 120 mm,
 shelf W 404 x D 288 mm, weight 1.5 kg

12 Keyboard and mouse platform with folding arm

for flexible mounting in the system grooves of Rocholz mounting profiles with perforation, support column (509001, 509002, 509006), profile rail (509005) or upright adapter (509003), platform 640 x 172 mm, tiltable up to 25°, rotatable and swivelling, max. reach 728 mm
max. surface load 10 kg

Art. 509201 W 640 x D 728 x H 120 mm, weight 3.5 kg

13 Folding support arm with tray

for flexible attachment in the system grooves of the Rocholz mounting profiles with perforation or on the upright adapter (509004), fixed adjustable inclination at 0°, 15° and 30°, tray area W 300 x D 400 mm, arm length 350 mm, max. surface load 30 kg
for holding e.g. devices, machines and boxes

Art. 509245 W 100 x H 201 mm, arm length 350 mm, weight 3.96 kg
 Art. 509246 W 100 x H 201 mm, arm length 500 mm, weight 4.77 kg
 Art. 509247 W 100 x H 201 mm, arm length 700 mm, weight 4.6 kg



14 Shelf with retracting keyboard tray

for hanging into the system perforation of the Rocholz mounting profiles with perforation, incl. carrier arm, shelf and retracting keyboard tray with pull-out mouse tray, horizontally movable

depth 300 mm

Art. 73316500 W 800 x T 300 mm, weight 8.2 kg, ruby red
 Art. 73316600 W 1,000 x T 300 mm, weight 9.1 kg, ruby red
 Art. 73316501 W 800 x T 300 mm, weight 8.2 kg, gentian blue
 Art. 73316601 W 1,000 x T 300 mm, weight 9.1 kg, gentian blue

depth 400 mm

Art. 73308600 W 800 x T 400 mm, weight 10 kg, ruby red
 Art. 73308700 W 1,000 x T 400 mm, weight 12.5 kg, ruby red
 Art. 73308601 W 800 x T 400 mm, weight 10 kg, gentian blue
 Art. 73308701 W 1,000 x T 400 mm, weight 12.5 kg, gentian blue

Single retracting keyboard tray

mouse tray can be pulled out to the left or right, under-table mounting, interior dimensions keyboard tray W 527 x D 250 mm, RAL 9006 white aluminium

minimum tabletop thickness 25 mm

Art. 509318 W 577 x D 290 x H 119 mm, weight 4.1 kg



Watch video

Trays and holders for printers can be found on pages 32 & 49.

15 4-socket outlet

for attachment to the system grooves of the Rocholz profiles with perforation using the supplied assembly kit, black

power connection 230 V, 16 A

- Art. 73311600 W 61 x D 45 x H 304 mm, weight 0.7 kg, without power cable
- Art. 73310200 Power cable 3 m, weight 0.4 kg
- Art. 73311400 Connecting cable 2,5 m, weight 0.3 kg

Socket strip

fixed mounted power supply cable 3 m, ideal for connecting angled plugs by aligning the sockets at a 90° angle with a large gap, attachment via magnetic adhesive tape supplied (not shown in image)

max. power limit 3,500 W

- Art. 509500 6-way with switch, weight 0.72 kg
- Art. 509501 5-way and 2-way USB with switch, weight 0.75 kg

16 Installation panel

for mounting between the Rocholz mounting profiles with perforation, **WITHOUT** power supply/connecting cable

mit 4-fach Steckdose

- Art. 73317100 W 800 x D 30 x H 80 mm, weight 1.1 kg, ruby red
- Art. 73317200 W 1,000 x D 30 x H 80 mm, weight 1.35 kg, ruby red
- Art. 73317101 W 800 x D 30 x H 80 mm, weight 1.1 kg, gentian blue
- Art. 73317201 W 1,000 x D 30 x H 80 mm, weight 1.35 kg, gentian blue



17 Cable clips

for cable management on Rocholz profiles with perforation, black

1 sales unit = 10 pcs.

- Art. 73312200 weight 0.06 kg



18 Cable tray

for attachment in the system groove of the functional struts

- Art. 73600088 W 600 x D 125 x H 116 mm, weight 1.24 kg
- Art. 73600026 W 800 x D 125 x H 116 mm, weight 1.66 kg
- Art. 73314800 W 61 x D 45 x H 304 mm, weight 0.35 kg, 4-socket outlet black, without power supply cable
- Art. 73310200 Power supply cable 3 m, weight 0.4 kg
- Art. 73311400 Connecting cable 2.5 m, weight 0.3 kg



19 Cable duct

for attachment to shelves

on double-sided shelves, the duct also functions as a gap cover

- Art. 73312700* W 730 x D 72 x H 93 mm, weight 1.6 kg
- Art. 73312800** W 930 x D 72 x H 93 mm, weight 2.3 kg
- Art. 73314800 W 61 x D 45 x H 304 mm, 4-socket outlet black, without power supply cable, weight 0.35 kg
- Art. 73310200 Power supply cable 3 m, weight 0.4 kg
- Art. 73311400 Connecting cable 2.5 m, weight 0.3 kg

* for mounting width 800 mm ** for mounting width 1,000 mm



Accessories
perforated back
panel from
page 116

1 Perforated back panel

for screwing into the system grooves of the Rocholz mounting profiles with perforation, fits flush (in depth) with the Rocholz mounting profiles at the front and back

infinitely height-adjustable

Art. 73305500	W 800 x D 30 x H 100 mm, weight 1.1 kg, ruby red
Art. 73302200	W 800 x D 30 x H 200 mm, weight 1.7 kg, ruby red
Art. 73303400	W 800 x D 30 x H 500 mm, weight 3.3 kg, ruby red
Art. 73305900	W 1,000 x D 30 x H 100 mm, weight 1.5 kg, ruby red
Art. 73302300	W 1,000 x D 30 x H 200 mm, weight 2.3 kg, ruby red
Art. 73306002	W 1,000 x D 30 x H 500 mm, weight 4.2 kg, ruby red
Art. 73305501	W 800 x D 30 x H 100 mm, weight 1.1 kg, gentian blue
Art. 73302201	W 800 x D 30 x H 200 mm, weight 1.7 kg, gentian blue
Art. 73303401	W 800 x D 30 x H 500 mm, weight 3.3 kg, gentian blue
Art. 73305901	W 1,000 x D 30 x H 100 mm, weight 1.5 kg, gentian blue
Art. 73302301	W 1,000 x D 30 x H 200 mm, weight 2.3 kg, gentian blue
Art. 73306001	W 1,000 x D 30 x H 500 mm, weight 4.2 kg, gentian blue

2 Shelf dividers open

galvanised, for inserting into the shelf perforations, perforation pattern 50 mm, 1 sales unit = 4 pcs.

Art. 73308800 W 300 x H 400 mm, weight 1.76 kg



3 Stop edge

for screwing onto the front of a shelf

continuous edge with full use of shelf depth

Art. 73302000	W 800 mm, weight 0.5 kg, ruby red
Art. 73309400	W 1,000 mm, weight 0.6 kg, ruby red
Art. 73314100	W 1,600 mm, weight 0.8 kg, ruby red
Art. 73302001	W 800 mm, weight 0.5 kg, gentian blue
Art. 73309401	W 1,000 mm, weight 0.6 kg, gentian blue
Art. 73314101	W 1,600 mm, weight 0.8 kg, gentian blue

4 Partition

for inserting into shelf perforations, 50 mm perforation pattern

for 300 mm deep shelves

Art. 73314700 W 298 x H 180 mm, weight 0.46 kg



Watch video

5 Stop bracket

for inserting into the shelf perforation rows, 50 mm perforation pattern, black

Art. 73301900 W 250 mm, weight 0.16 kg

6 Utensil shelf

for hooking into the system perforations of the Rocholz mounting profiles with perforation, for storing adhesive rolls etc., incl. four dividers

inclined 0° and 20°

Art. 73312500	W 800 x D 200 x H 100 mm, weight 3.5 kg, ruby red
Art. 73312600	W 1,000 x D 200 x H 100 mm, weight 4.06 kg, ruby red
Art. 73312501	W 800 x D 200 x H 100 mm, weight 3.5 kg, gentian blue
Art. 73312601	W 1,000 x D 200 x H 100 mm, weight 4.06 kg, gentian blue
Art. 122052	dividers 2 pcs., weight 0.1 kg

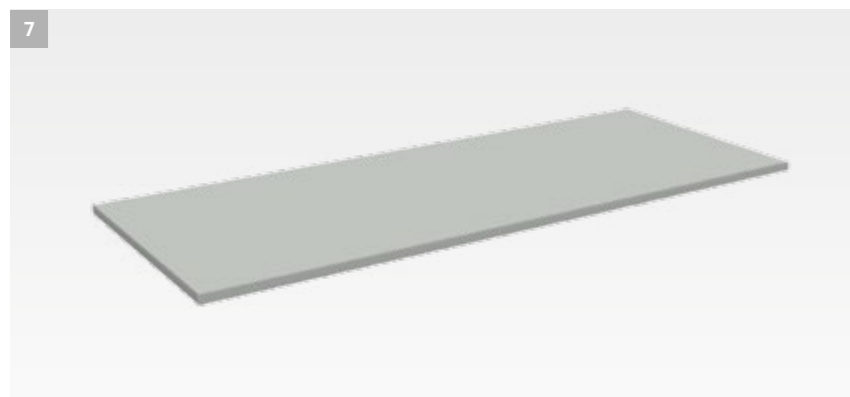

Watch video

7 Bottom shelf

max. surface load 50 kg

for tables without electrical height adjustment

Art. 73300400	W 1,195 x D 650 x H 19 mm, weight 13.1 kg
Art. 73300500	W 1,595 x D 650 x H 19 mm, weight 17.2 kg
Art. 73308400	W 1,995 x D 650 x H 19 mm, weight 20.3 kg

for tables with electrical height adjustment

Art. 73300401	W 978 x D 600 x H 19 mm, weight 12 kg
Art. 73300501	W 1,378 x D 600 x H 19 mm, weight 16 kg
Art. 73300601	W 1,778 x D 600 x H 19 mm, weight 20 kg

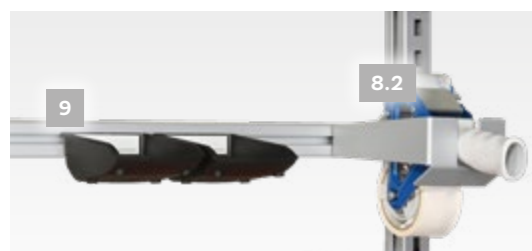

8 Holder for adhesive tape dispenser

for attachment in the system groove of the Rocholz profiles with perforation or to the SYSTEM FLEX multifunctional rail

8.1	Art. 73308200	W 110 x D 38 x H 78 mm, for attachment to the Rocholz profile, weight 0.22 kg
8.2	Art. 73316800	W 105 x D 183 x H 78 mm, for attachment to the multifunctional rail, weight 0.5 kg

9 Multifunctional rail

for screwing into the system groove between the Rocholz mounting profiles with perforation, RAL 9006 white aluminium, max. load capacity 25 kg

enables mounting various accessories

Art. 73303301	W 800 mm, weight 2.81 kg
Art. 73303300	W 1,000 mm, weight 3.6 kg

10 Lateral crush protection

for screwing into the system grooves of the functional struts

Art. 73601081	W 715 x D 49 x H 565 mm, weight 6.2 kg, ruby red
Art. 73601147	W 715 x D 49 x H 565 mm, weight 6.2 kg, gentian blue



11 Bottle holder

for flexible attachment in the system groove of the functional struts, in RAL 9006 white aluminium
holder for two bottles with max. 1,5 l

Art. 73308500	W 210 x D 125 x H 130 mm, weight 0.98 kg
---------------	--

12 Bin liner holder

can be attached in the system groove of the functional struts, incl. adapter for attachment to the table top (SYSTEM 2000 and MODUL 5000), in RAL 9006 white aluminium
suitable for standard 120 l bin liners

Art. 73315903	W 329 x D 319 x H 52 mm, weight 1.4 kg
---------------	--

13 Holder for pens, cable ties etc.

incl. bracket for attachment in the system groove of the Rocholz profiles, Ø 80 mm, in RAL 9006 white aluminium

Art. 73600086	W 87 x D 195 x H 128 mm, useable height 100 mm, weight 0.98 kg
Art. 73600253	W 87 x D 195 x H 280 mm, useable height 200 mm, weight 1.42 kg



Watch video

14 Drawer with extension

horizontally adjustable, for mounting under shelves 400 mm deep, in RAL 9006 white aluminium

max. surface load 15 kg

Art. 73600040 W 398 x D 348 mm,
for 800 mm wide shelves, weight 3.8 kg

Art. 73600015 W 398 x D 348 mm,
for 1,000 mm wide shelves, weight 4.75 kg

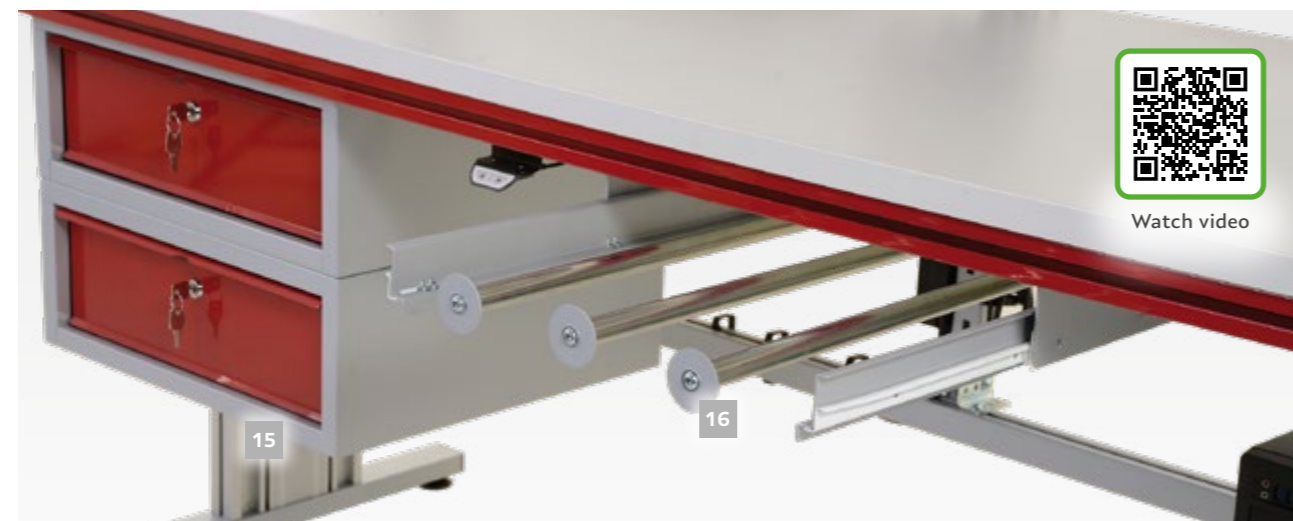
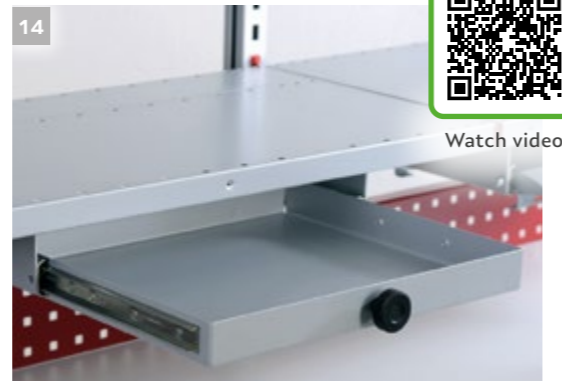

15 Drawer lockable

useable dimensions W 450 x D 445 x H 120 mm, incl. assembly set, body in RAL 9006 white aluminium

max. surface load 35 kg

Art. 73314500 Single drawer ruby red,
W 527 x D 510 x H 200 mm, weight 17.7 kg

Art. 73314600 Supplement drawer ruby red,
W 527 x D 510 x H 200 mm, weight 15 kg

Art. 73314501 Single drawer gentian blue,
W 527 x D 510 x H 200 mm, weight 17.7 kg

Art. 73314601 Suppl. drawer gentian blue,
W 527 x D 510 x H 200 mm, weight 15 kg



16 Extendable pole unit

for under-table mounting in the system groove of the functional struts, infinitely variable extension from under the table, in RAL 9006 white aluminium

Extendable up to 500 mm

Art. 73315500 W 515 x D 715 x H 124 mm, weight 11 kg

17 Under-table dividers

for cardboard boxes, for attachment in the system groove of the functional struts, galvanised, cannot be used in combination with bottom shelves

Art. 73600504 W 463 x H 753 mm, weight 0.6 kg



18 Under-table retracting shelf

useable area W 405 x D 660 x H 445 mm, cannot be used in combination with bottom shelves

max. surface load 50 kg

Art. 73315900 W 460 x D 755 x H 563 mm, weight 26 kg



19 Workspace extension

extension length 500 mm, useable area W 500 x D 500 mm, surface in RAL 9006 white aluminium

max. surface load 50 kg

Art. 73312300 W 547 x D 715 x H 118 mm,
weight 11 kg, ruby red

Art. 73312301 W 547 x D 715 x H 118 mm,
weight 11 kg, gentian blue



20 Foldable work surface extension

simple folding out and in of extension via lever, drill holes in feet must be implemented by the customer

for retrofitting

Art. 73101200 W 410 x D 800 x H 30 mm, weight 6.5 kg

21 Flyer storage

with insertable dividers 800 mm, for attachment in the system perforation of the Rocholz mounting profiles with perforation, RAL 9006

compartment size min. W 108 x D 210 mm

Art. 73318200 W 797 x D 227 x H 102 mm, with 6 dividers,
weight 4.8 kg

Art. 73318100 W 997 x D 227 x H 102 mm, with 8 dividers,
weight 6.1 kg

Art. 73318000 Depth adjustment plate, W 107 x H 98.5 mm,
weight 0.15 kg





22 Roll holder next to the table

carrier arms with spindle set and assembly set incl. floor mounting bracket, for fastening in the system groove of the Rocholz profiles with perforation, max. roll weight 25 kg, max. roll diameter Ø 800 mm

Roll width up to 750 mm

Art. 73304000 W 1,000 x D 450 x H 100 mm, weight 4.7 kg



23 Roll holder under the table

consisting of 1 pair of cones, 4 clamp rings, 1 spindle and 2 bearing shells; spindle tube Ø 32 mm, max. roll weight 100 kg

- Art. 73313100 for table width 1,200 mm, max. roll width 750 mm, weight 3 kg
- Art. 73313200 for table width 1,600 mm, max. roll width 1,250 mm, weight 4.2 kg
- Art. 73313300 for table width 2,000 mm, max. roll width 1,600 mm, weight 4.8 kg

24 Roll holder between the Rocholz mounting profiles with perforation

with cones and clamp rings, incl. two bearing shells, for attachment between the Rocholz profiles with perforation, max. roll weight 25 kg

- Art. 73315010 W 800 mm, weight 2 kg
- Art. 73315110 W 1,000 mm, weight 2.3 kg



25 Add-on cutter

for hooking into the system perforation of the Rocholz mounting profiles with perforation, cutting width 500 or 750 mm

- Art. 73601254 W 800 x D 50 x H 150 mm, weight 7.8 kg
- Art. 73303900 W 1,000 x D 50 x H 150 mm, weight 7.8 kg

26 Castor set

for height-adjustable packing tables, 4 castors, 2 with brake function

- Art. 2030-2 Ø 125 mm, height 162 mm, weight 3.8 kg
- Art. 203502 Ø 50 mm (Dual role), height 69 mm, weight 3,8 kg



Further cutting systems page 124

1 SYSTEM FLEX – Basic equipment theme package

three shelves (73307000) with two open shelf dividers (73308800), Utensilo (73312500), holder for adhesive tape dispenser (73308200)

Art. 73805203 weight 25 kg

2 SYSTEM FLEX – Ergonomics theme package

workplace lighting (73315610), bottle holder (73308500), ergonomic workplace mat (600004)

Art. 73805201 weight 19.4 kg

3 SYSTEM FLEX – IT theme package

monitor holder (509204), keyboard and mouse platform (509201), 4-way socket (73311600), power supply cable (73310200) and cable clips (73312200)

Art. 73805202 weight 8 kg



i All theme packages shown here are available for SYSTEM FLEX and FLEX Light.

SYSTEM 2000

A fine combination!
SYSTEM 1600 & SYSTEM 2000
are combined
to the new
SYSTEM 2000.

With SYSTEM 2000, we offer you two complete all-in-one solutions with a 1,600 mm wide table top. Either with a bottom shelf and steel drawer or with a roll holder and add-on cutter – depending on the intended use. Alternatively, we also offer customised individual solutions with a tabletop width of 2,000 mm.



Complete packing stations with 1,600 mm wide table top, document shelf and carton storage rack.

- sturdy table in steel construction
- 30 mm table top
- max. surface load 300 kg
- table top light grey melamine resin-coated
- steel components powder-coated anthracite RAL 7016, ruby red RAL 3003

i The add-on cutter is supplied with two cutter cartridges. The smooth blade is for foil and the round serrated blade for paper and cardboard. The cartridges can be replaced effortlessly.

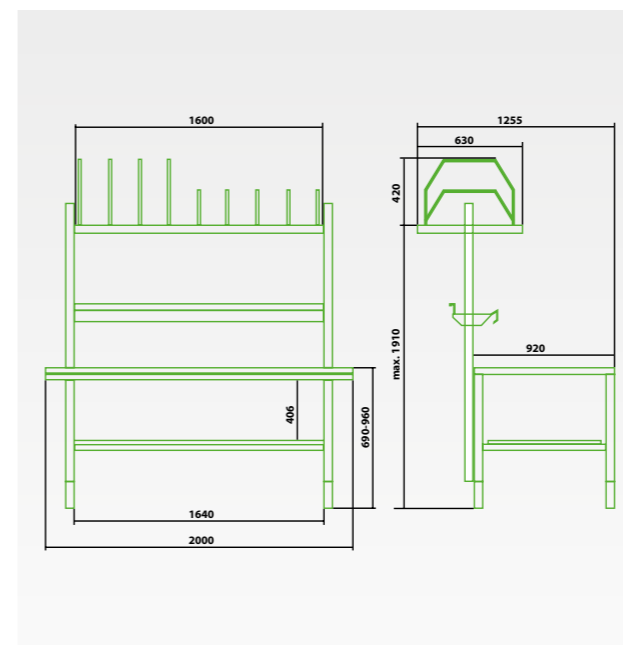

ACCESSORIES

Do you need additional accessories? No problem, the all-in-one complete packing stations can be extended with accessories from the SYSTEM 2000 range of accessories. You are welcome to put together your own custom solution on the following pages.

SYSTEM 2000 is height-adjustable as standard.



1 SYSTEM 2000 complete solution 1,600 mm

height-adjustable 690-960 mm, sturdy steel construction, struts and feet made of 40 x 40 mm square tubing, tabletop plastic-coated light grey (similar to RAL 7035), incl. storage rack, document shelf, steel drawer and bottom shelf (1135 x 650 mm), max. surface load 300 kg

with bottom shelf

1.1 Art. 163001 W 1,600 x D 800 x H 690 - 960 mm, weight 100 kg

height-adjustable 690-960 mm, sturdy steel construction, struts and feet made of 40 x 40 mm square tubing, table top plastic-coated light grey (similar to RAL 7035), incl. storage rack, document shelf, cutter (cutting width 1,000 mm), with 2 cutter cartridges, spindle set with cones and bearing shells, max. roll weight 100 kg, max. surface load 300 kg

with cutter

1.2 Art. 163002 W 1,600 x D 800 x H 690 - 960 mm, weight 115 kg

2 SYSTEM 2000 packing and work table

height-adjustable, sturdy steel construction, struts and feet made of 40 x 40 mm square tubing, 30 mm melamine resin-coated table top, max. surface load 300 kg

Art. 123034	W 1,200 x D 800 x H 690-960 mm, weight 38 kg
Art. 163000	W 1,600 x D 800 x H 690-960 mm, weight 49 kg
Art. 163500	W 1,600 x D 800 x H 710-960 mm (adjustable via crank), weight 50 kg
Art. 163800	W 1,600 x D 800 x H 710-960 mm (electrically adjustable, max. lifting speed 15 mm/sec, with 4-fold height memory), weight 55 kg
Art. 203000	W 2,000 x D 920 x H 690-960 mm, weight 58 kg
Art. 203500	W 2,000 x D 920 x H 710-960 mm (adjustable via crank), weight 59 kg
Art. 203800	W 2,000 x D 920 x H 710-960 mm (electrically adjustable, max. lifting speed 15 mm/sec, with 4-fold height memory), weight 66 kg

3 SYSTEM 2000 packing and work table with scale

table like 203000, weighing range up to 60 kg, scale division 20 g, stainless steel platform, weighing area 400 x 500 mm, with separate display unit (without holder), max. surface load 300 kg

legal-for-trade scale with RS232 computer interface

Art. 203210	W 2,000 x D 920 x H 690-960 mm, weight 75 kg
Art. 203534	W 2,000 x D 920 x H 710-960 mm (adjustable via crank), weight 84 kg
Art. 203834	W 2,000 x D 920 x H 710-960 mm (electrically adjustable, max. lifting speed 15 mm/sec, with 4-fold height memory), weight 67 kg

table like 203000, weighing range up to 60 kg, scale division 20 g, stainless steel platform, weighing area 400 x 500 mm, with separate display unit (without holder), max. surface load 300 kg

for non-legal-for-trade weighing

Art. 203200	W 2,000 x D 920 x H 690-960 mm, weight 71 kg
Art. 203530	W 2,000 x D 920 x H 710-960 mm (adjustable via crank), weight 73 kg
Art. 203830	W 2,000 x D 920 x H 710-960 mm (electrically adjustable, max. lifting speed 15 mm/sec, with 4-fold height memory), weight 87 kg

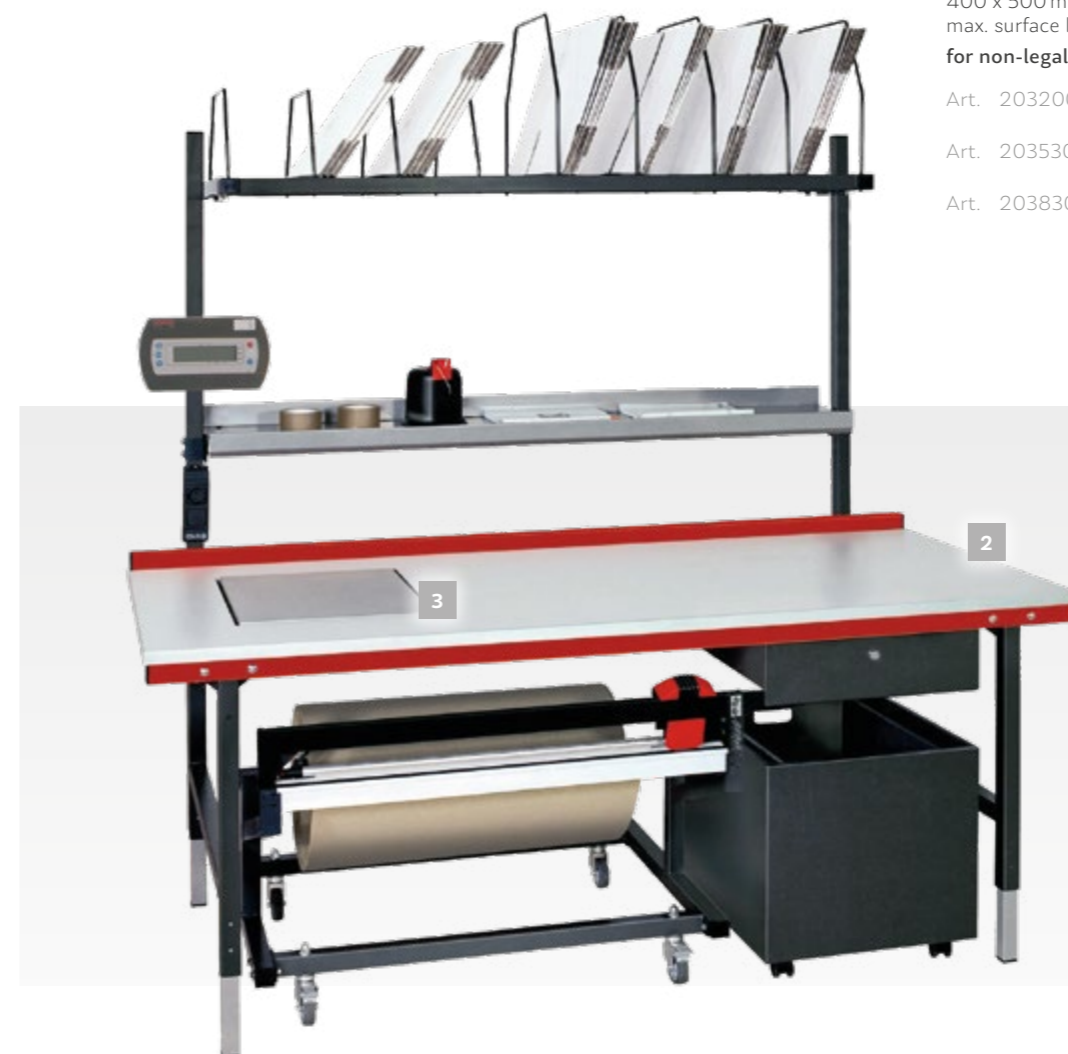

i Scales can also be optionally positioned on the right or in the centre!

The scale display unit can be attached to a separately available bracket (p. 65).

1 Roller track table

plastic rollers Ø 50 mm x W 600 mm, roller division 75 mm, roller area inclinable

max. surface load 150 kg

Art. 203020 W 1,955 x D 640 x H 690-960 mm, weight 43 kg
 Art. 203520 W 1,955 x D 640 x H 710-960 mm, adjustable via crank, weight 46 kg

Roller track table with scale

stainless steel platform, weighing area 600 x 600 mm, scale division 20 g, with separate display unit, plastic rollers Ø 50 mm x W 600 mm, roller division 75 mm, max. surface load 150 kg

for weighing up to 60 kg

Art. 203021 W 1,955 x D 640 x H 690-960 mm, weight 69 kg
 Art. 203022 W 1,955 x D 640 x H 690-960 mm, calibratable with EDP interface, weight 69 kg



2 Roller track table with work surface

work surface W 1,955 x D 300 mm made of galvanised sheet steel, plastic rollers Ø 50 mm x W 600 mm (5 mm higher than work surface), roller division 75 mm

Art. 203010 W 1,955 x D 920 x H 690-960 mm, max. surface load 120 kg, weight 63 kg

Art. 203510 W 1,955 x D 920 x H 710-960 mm, adjustable via crank, max. surface load 150 kg, weight 67 kg



3 Roller track table with work surface and scale

work surface W 1,955 x D 300 mm made of galvanised sheet steel, weighing area 600 x 600 mm, scale division 20 g, with separate display unit, plastic rollers Ø 50 mm x W 600 mm (5 mm higher than work surface), roller division 75 mm, max. surface load 120 kg

for weighing up to 60 kg

Art. 203011 W 1,955 x D 920 x H 690-960 mm, weight 94 kg
 Art. 203012 W 1,955 x D 920 x H 690-960 mm, calibratable with EDP interface, weight 94 kg

4 Locking plate

simply attach and stop the flow, for roller track tables with a roller track width of 600 mm + 75 mm division

galvanised surface

Art. 203544 W 600 x D 125 x H 62.5 mm, weight 1.4 kg

5 End stop for roller track tables

limiter for parcels and packages on the roller track

Art. 203541 W 600 x D 10 x H 100 mm, weight 2.9 kg



6 Side guard for roller track tables

limiter for safely guiding packages and parcels on the roller track

Art. 203540 W 1,955 x D 20 x H 70 mm, weight 3 kg



1 Uprights

with screw attachment to table legs, sales unit = 2 pcs.

short or long version

Art. 2062 L 1,170 mm, short, 485 mm above table, weight 6 kg
 Art. 2064 L 1,770 mm, long, 1,085 mm above table, weight 8 kg
 Art. 2065* L 1,170 mm, short, 485 mm above table, weight 4 kg
 Art. 2066* L 1,770 mm, long, 1,085 mm above table, weight 13 kg

* for height-adjustable tables

2 Mounting frame

alternative for attaching accessories, suitable for height-adjustable tables and roller tracks

can be combined with all tables

Art. 206411 W 1,215 x D 810 x H 1,800 mm, weight 26 kg, for table width 1,600 mm
 Art. 206410 W 1,800 x D 810 x H 1,800 mm, weight 29 kg, for table width 2,000 mm



WHICH UPRIGHT FITS WHICH TABLE?

Upright	2062	2064	2065	2066	206411 (for width 1,200 & 1,600 mm)	206410 (for width 2,000 mm)
Packing table						
123034, 163000	●	●			●	
163500, 163800			⚡ ⚡	⚡ ⚡	●	
203000, 203200, 203210	●	●				●
203500, 203532, 203533, 203800, 203832, 203833, 203530			⚡ ⚡	⚡ ⚡		●
Roller track table						
203020, 203021, 203022, 203520, 203521, 203522						●
203010, 203011, 203012	●	●				●
203510, 203511, 203512			⚡ ⚡	⚡ ⚡		●
Use without table					●	●



The uprights or the mounting frame are the basis for all accessories above the packing table. Please note that suitably sized accessories are available for table widths 1200, 1600 and 2000. Your local specialist dealer will be happy to advise you.

1 Storage rack

flexible clamp mounting
max. surface load 50 kg

- Art. 1653 W 1,015 x D 600 x H 400 mm, weight 20 kg, for approx. 100 folding cartons, with 3 small and 3 large dividers, for table width 1,600 mm
- Art. 1653D without dividers, e.g. for installing retracting shelf for printers, weight 17 kg
- Art. 2053 W 1,600 x D 600 x H 400 mm, weight 28 kg, for approx. 160 folding cartons, with 5 small and 4 large dividers, for table width 2,000 mm
- Art. 2053D without dividers, e.g. for installing retracting shelf for printers, weight 25 kg

2 Storage shelf

30 mm melamine resin-coated wood, flexible clamp mounting
max. surface load 50 kg

- Art. 704740 W 1,046 x D 400 mm, weight 6 kg, for table width 1,600 mm
- Art. 704750 W 1,600 x D 400 mm, weight 15 kg, for table width 2,000 mm

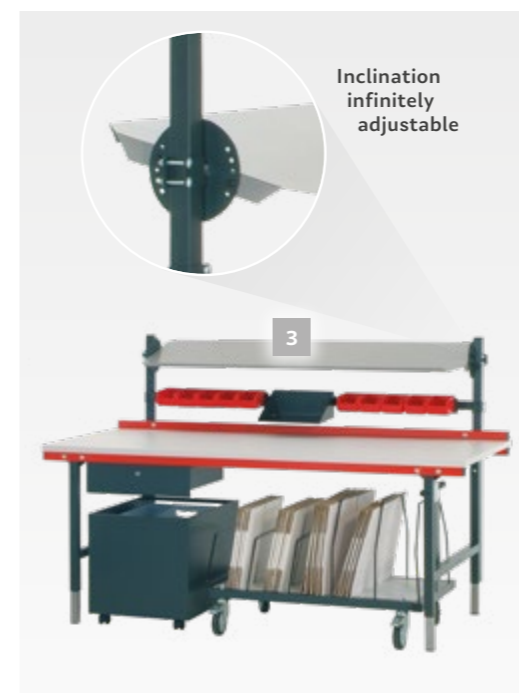

3 Inclined shelf

made of sheet steel, flexible clamp mounting, infinitely adjustable inclination, with non-slip edge
max. surface load 50 kg

- Art. 704700 W 1,045 x D 450 x H 60 mm, weight 10 kg, for table width 1,600 mm
- Art. 704800 W 1,630 x D 450 x H 60 mm, weight 19 kg, for table width 2,000 mm

4 Side table

coated table top light grey (similar to RAL7035), max. surface load 100 kg
for e.g. package scale

- Art. 209000 W 600 x D 600 x H 770 mm, weight 17 kg
- Art. 209034 W 600 x D 600 x H 605-875 mm, weight 19 kg

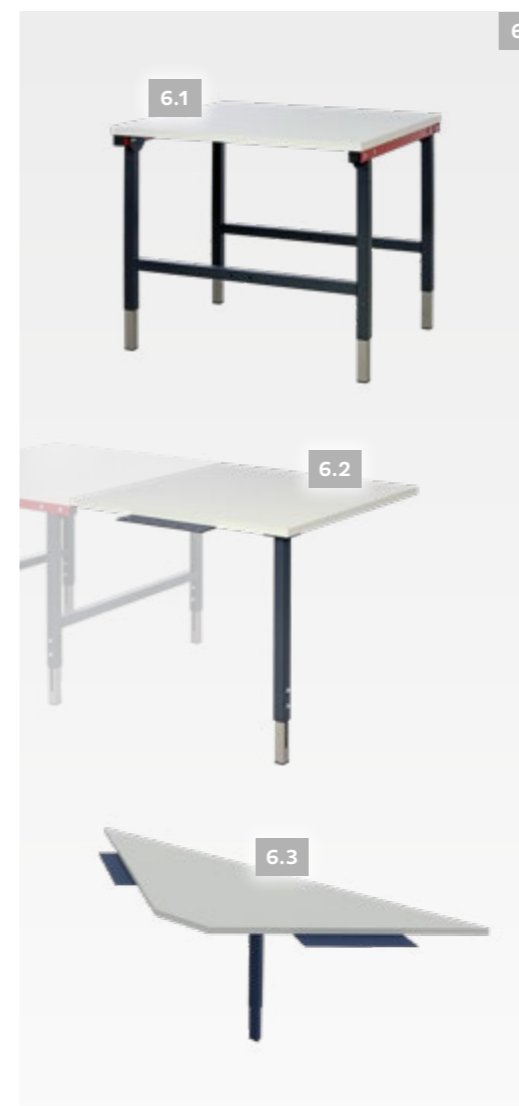

5 Document shelf

made of sheet steel, flexible clamp mounting
max. surface load 25 kg

- Art. 1650 W 1,045 x D 230 mm, weight 5 kg, for table width 1,600 mm
- Art. 2050 W 1,630 x D 230 mm, weight 7 kg, for table width 2,000 mm

6 Corner tables

- 6.1 Art. 203100 W 920 x D 920 x H 690-960 mm, free-standing with 4 legs, max. surface load 300 kg, weight 38 kg
- 6.2 Art. 203110 W 920 x D 920 x H 690-960 mm, attached, square with stand leg, max. surface load 50 kg, weight 35 kg
- 6.3 Art. 203120 W 920 x D 700 x H 690-960 mm, attached, trapezoid with stand leg, max. surface load 50 kg, weight 15 kg

7 Backboard

square tubing 40 x 40 mm, ruby red

Art. 126000	W 1,200 x D 40 x H 40 mm, weight 3.2 kg
Art. 166000	W 1,600 x D 40 x H 40 mm, weight 4.2 kg
Art. 206000	W 2,000 x D 40 x H 40 mm, weight 5.2 kg

8 Bottom shelf

max. surface load 100 kg

Art. 160900	W 1,135 x D 650 x H 19 mm, weight 16 kg, for table width 1,600 mm
Art. 200900	W 1,720 x D 770 x H 19 mm, weight 25 kg, for table width 2,000 mm



9 Backboard with power strip

power strip useable with sockets no. 2072

4-socket strip incl. plastic cover

Art. 208516	W 1,590 x D 50 x H 100 mm, weight 8 kg, for table width 1,600 mm
Art. 208520	W 1,890 x D 50 x H 100 mm, weight 11 kg, for table width 2,000 mm

10 Cover rail

cover between the uprights (for double workplaces)

made of sheet steel in RAL 7016 anthracite

Art. 163003	W 1,055 x D 40 mm, weight 2 kg, for table width 1,600 mm
Art. 203003	W 1,640 x D 40 mm, weight 3 kg, for table width 2,000 mm

Further IT accessories from page 110

SURFACES

- **Melamine resin coating**
for packing and order picking work
- **Conductive (ESD protection)**
for assembling and packing electronic components
- **Plywood boards/multiplex**
for extreme mechanical strain and loads
- **Stainless steel**
for workplaces where people work with oil, acids or other fluids

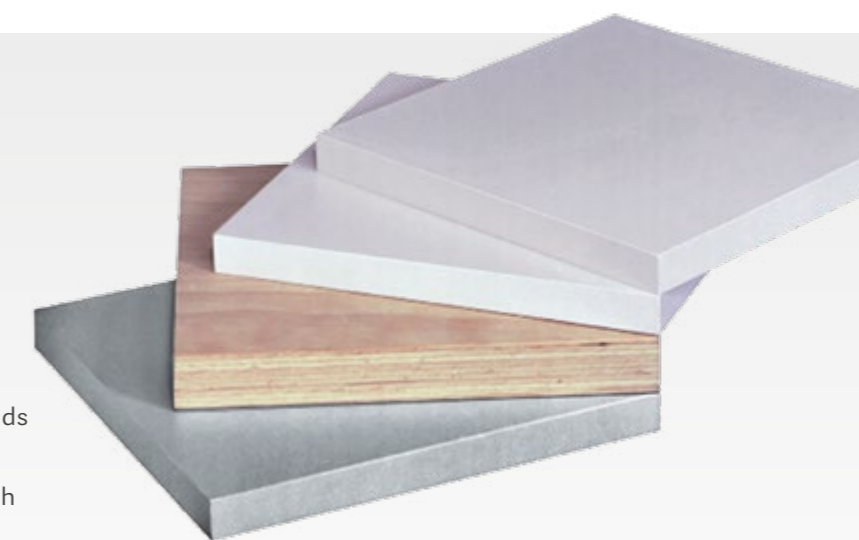



1

1 Workplace lighting Slim LED

for mounting on the SYSTEM 2000 storage rack (1653, 2053, 1653D und 2053D) or on the holder for workplace lighting, 4,000 K, incl. external power supply unit

Art. 207005 W 889 x D 32 x H 26.5 mm,
923 lx, 2,500 lm, weight 0.34 kg

Image on SYSTEM FLEX



2 Workplace lighting LED

sturdy aluminium casing, for mounting under the SYSTEM 2000 storage rack (1653, 2053, 1653D und 2053D) or to the holder for workplace lighting, 4,000 K, 0.15 A, protection rating IP30, incl. 4 m connection cable
can be adapted to lighting requirements with dimming function

Art. 207003 W 976 x D 51 x H 54 mm, 32 W, 3368 lm, weight 1.8 kg
Art. 207004 W 661 x D 51 x H 54 mm, 21 W, 2158 lm, weight 1.5 kg

3 Holder for workplace lighting

attachment to the uprights

Art. 207002 W 1,145 x D 515 x H 40 mm, for table width 1,600 mm, weight 5.6 kg
Art. 207001 W 1,730 x D 455 x H 40 mm, for table width 2,000 mm, weight 6.6 kg

4 Holder for scale display unit

4.1 in RAL 9006 white aluminium

attachment to monitor folding arm with VESA 75 perforation

Art. 509206 W 120 x D 50 x H 100 mm, weight 0.5 kg

4.2 flexible clamp mounting on uprights

Art. 2091 W 120 x D 92 x H 42 mm, weight 0.56 kg

4.2



4.1

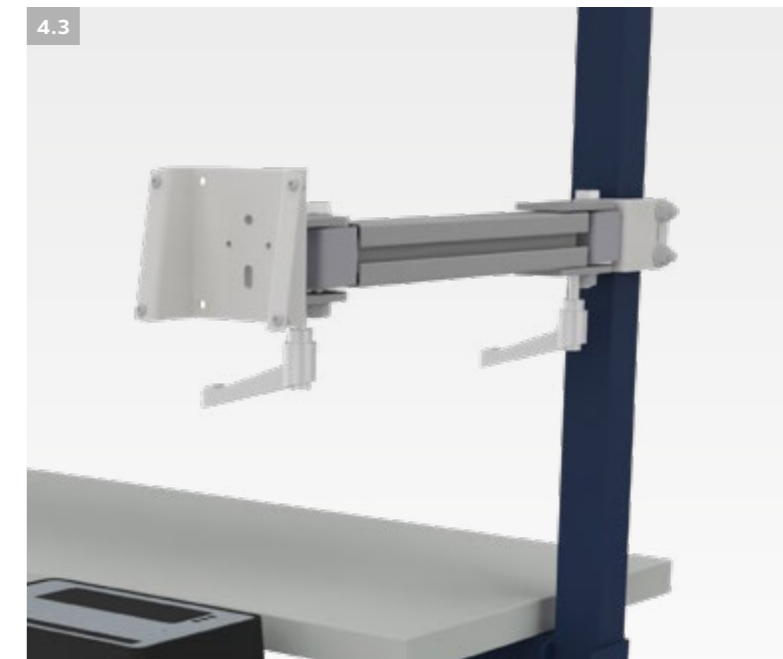

4.3

4.3 flexible attachment to uprights using the enclosed adapter, the data cable must at least be 2 m long, in RAL 9006 white aluminium, max. load capacity 15 kg

attachment to single folding arm

Art. 209204 W 217 x D 485 x H 142 mm, weight 2.5 kg

4.4 attachment to perforated back panel

Art. 509232 W 120 x D 50 x H 100 mm, weight 0.6 kg

4.4



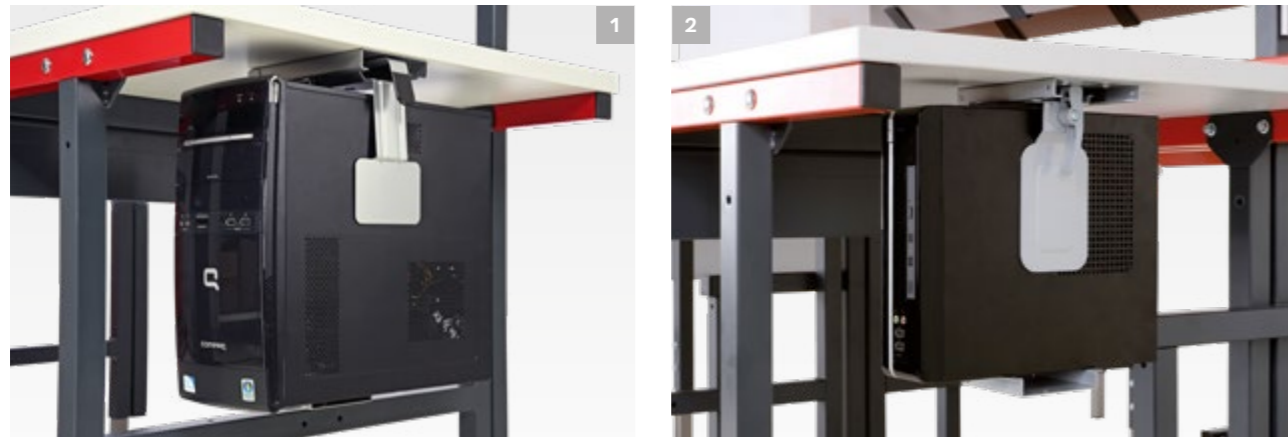

1 PC holder

for mounting under the table, incl. fastening screws and drilling template
adjustable: interior height 307 - 531 mm, interior width 78 - 220 mm

Art. 228100 W 100-242 x D 150 x H 320-545 mm, weight 3 kg
 Art. 228101 W 130 x D 240 x H 120 mm, adapter for mounting to upright or table leg, weight 0.9 kg

2 Mini PC holder

for mounting under the table, incl. fastening screws and drilling template
adjustable: interior height 205 - 360 mm, interior width 50 - 100 mm

Art. 228110 W 160 x D 115 x H 240-395 mm, weight 2 kg

3 Profile rail for folding arm for IT

attachment to upright with 2 clamp sections, with 3 fastening grooves suitable for double workplaces

Art. 509005 H 745 mm, weight 2 kg

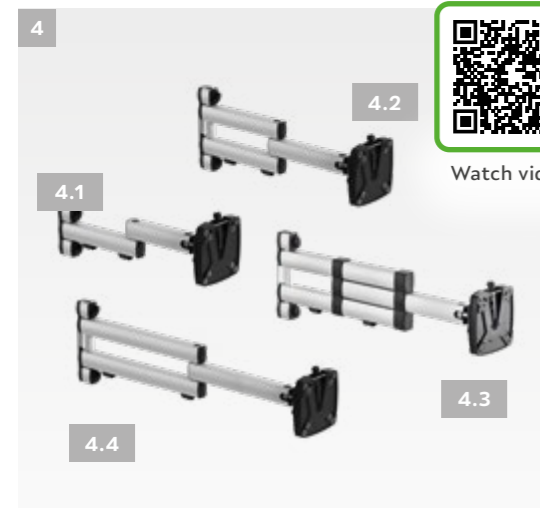

4 Monitor folding arm

for flexible attachment of a monitor in the system grooves of Rocholz profiles with perforation, support column (509001, 509002, 509006), profile rail (509005) or upright adapter (509003), incl. cable holder
VESA 75/100 quick-release attachment

- 4.1 Art. 509203 W 100 x D 450 x H 120 mm, weight 2 kg, max. load capacity 10 kg
- 4.2 Art. 509204 W 100 x D 505 x H 200 mm, weight 2.1 kg, max. load capacity 15 kg
- 4.3 Art. 509207 W 100 x D 456-704 x H 200 mm, weight 2.5 kg, max. load capacity 8 kg
- 4.4 Art. 509209 W 100 x D 700 x H 200 mm, weight 2.5 kg, max. load capacity 10 kg

5 Monitor support carriage

for flexible attachment of a monitor to the support column, profile rail, in the system groove of the Rocholz profiles with perforation or on the upright adapter (509003)
max. load capacity 12 kg

Art. 509202 W 100 x D 125 H 115 mm, weight 1 kg



6 Thin client holder for monitor folding arm

for attaching between monitor folding arm and monitor, the holder can be continuously adjusted to the width of the thin client, max. load capacity 7.5 kg
suitable for VESA 100 x 100 mm

Art. 509211 W 35-53 mm, weight 0.9 kg

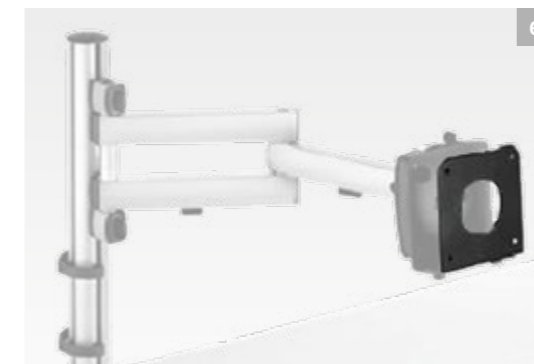

7 Tablet holder

for attaching to monitor folding arms (carrier arm not included), VESA 75/100 quick-release attachment, clamping range 160-300 mm
for tablets from 7" to 10"

Art. 509214 weight 0.5 kg

8 Upright adapter

adapter for folding arm and support carriage, for attaching monitor folding arms to the upright

Art. 509003 W 47 x D 67 x H 120 mm, weight 0.47 kg
 Art. 509004 W 47 x D 67 x H 200 mm, weight 0.8 kg

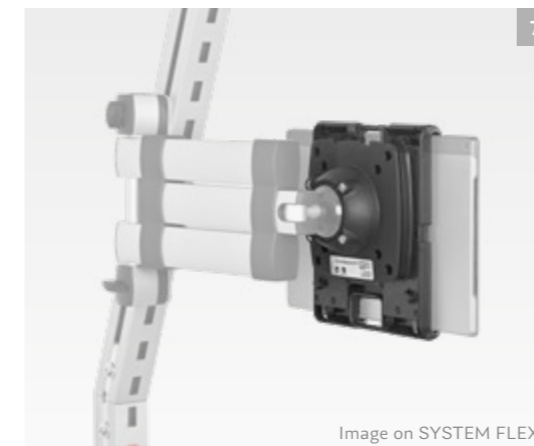

9 4-socket outlet

clamp mounting on the uprights, power connection 230 V, 16 A
incl. 3 m power supply cable

Art. 2074 W 61 x D 45 x H 304 mm, weight 1 kg



10 Keyboard and mouse platform with folding arm

for flexible attachment to the system groove of the Rocholz profile with perforation, support column (509001, 509002, 509006), profile rail (509005) or upright adapter (509003), platform 640 x 172 mm, tiltable up to 25°, rotatable and swivelling, reach 728 mm
max. surface load 10 kg

Art. 509201 W 640 x D 728 x H 120 mm, weight 3.5 kg

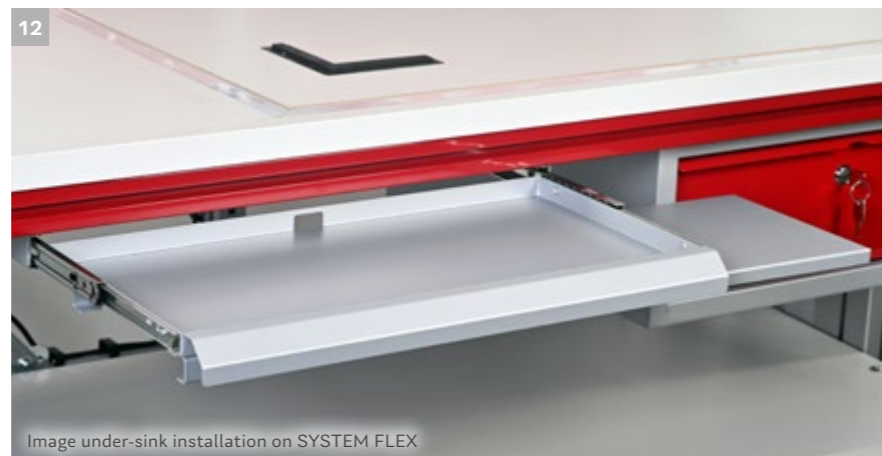

11 Keyboard and mouse platform

for mounting on universal shelf (2082) or storage shelf (704740, 704750)
with non-slip rubber surface

Art. 20812 W 760 x D 210 x H 20 mm, weight 5 kg

12 Retractable keyboard tray

extendable mouse tray can be pulled out to the left or right, under-table mounting, interior dimensions keyboard tray
 W 527 x D 250 mm, RAL 9006 white aluminium
minimum tabletop thickness 25 mm

Art. 509318 W 577 x D 290 x H 119 mm, weight 4.1 kg

13 Retracting keyboard and mouse platform

for mounting under storage shelf (704740, 704750) or under the table, made of plastic
space-saving holder

Art. 208120 W 600 x D 420 x H 110 mm, weight 2 kg

Further
IT accessories
from page 110



14 Universal shelf

clamp mounting on the uprights
max. surface load 25 kg

Art. 2082 W 440 x D 520 x H 90 mm, weight 8 kg

15 Retracting printer platform

for mounting on storage rack (2053, 1653), max. surface load 35 kg
retracting surface 375 x 617 mm

Art. 205350 W 375 x D 658 x H 100 mm, weight 11 kg

16 Printer trolley under-table version

mobile with 4 castors, 2 with brake function, in RAL 9006 white aluminium, max. surface load 50 kg
with storage compartment for paper

Art. 204251 W 500 x D 600 x H 240 mm, weight 20 kg

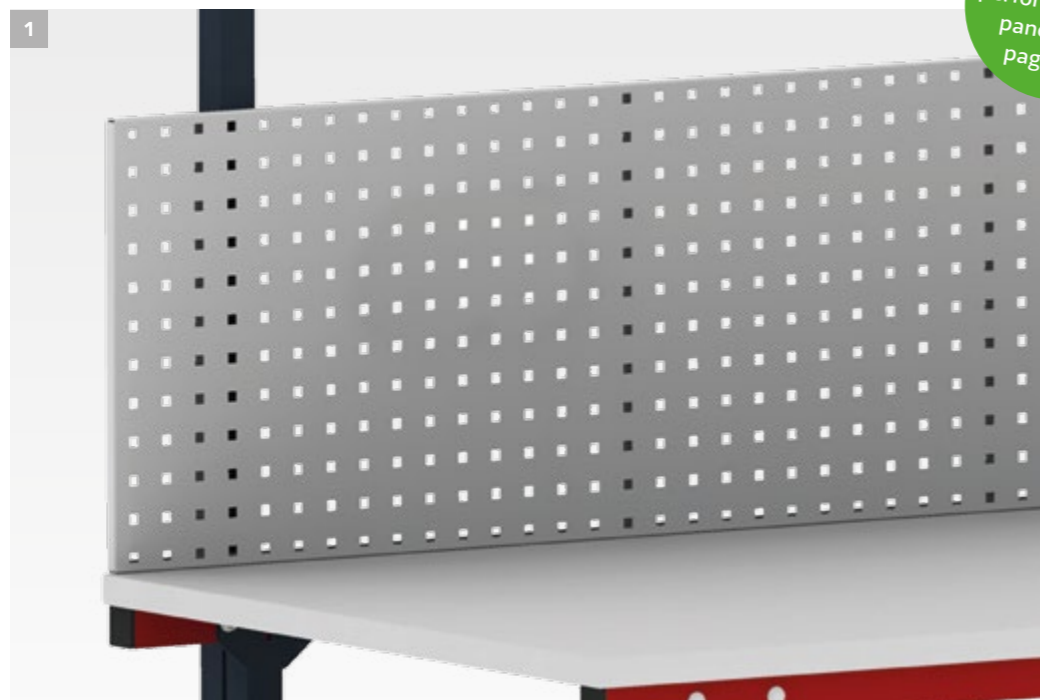

1 Perforated back panel

perforated panel for attaching additional accessories, in RAL 7035 light grey

- Art. 707016 W 1,500 x H 450 mm, weight 9 kg, for table width 1,600 mm
- Art. 707116 W 1,500 x H 450 mm, weight 8 kg, 1/3 slotted panel and 2/3 perforated plate, for table width 1,600 mm
- Art. 707020 W 2,000 x H 450 mm, weight 12 kg, for table width 2,000 mm

2 RasterPlan® hook range

impact and scratch-resistant coating; consisting of 3 x single hooks 50 mm, 3 x double hooks 75 mm, 3 x double hooks 150 mm, 1 x shelf 445 x 150 mm
"GS"-safety tested tool holder system

- Art. 707090 10 pieces, weight 1.5 kg

3 Holder for adhesive tape dispenser

for attaching to square tubing

- Art. 209205 W 90 x D 227 x H 78 mm, weight 0.5 kg

4 Bottle holder

holder for two bottles with max. 1.5l, for attachment to upright, in RAL 9006 white aluminium

- Art. 228200 W 207 x D 176 x H 129 mm, weight 0.9 kg

Further accessories for perforated back panel from page 116



5 Multifunctional rail

for attaching additional accessories

- Art. 704711 W 1,055 x D 40 x H 40 mm, weight 2 kg, for table width 1,600 mm
- Art. 704710 W 1,640 x D 40 x H 40 mm, weight 4 kg, for table width 2,000 mm

6 Label Utensilo

for mounting on the multifunctional rail (704711, 704710), incl. dividers, in RAL9006 white aluminium
practical one-hand use for removing roll labels

- Art. 705116 W 800 x D 200 x H 90 mm, weight 6 kg, for table width 1,600 mm, incl. 4 dividers
- Art. 705100 W 1,616 x D 200 x H 90 mm, weight 7 kg, for table width 2,000 mm, incl. 5 dividers
- Art. 122052 dividers, 2 pcs., weight 0.1 kg

7 Shelves

for mounting on multifunctional rail

holder incl. 5 storage bins size 7

- 7.1 Art. 704714 W 550 x D 218,5 x H 85 mm, weight 2 kg

Multipurpose shelf

- 7.2 Art. 705081 W 315 x D 240 x H 130 mm, weight 2.6 kg

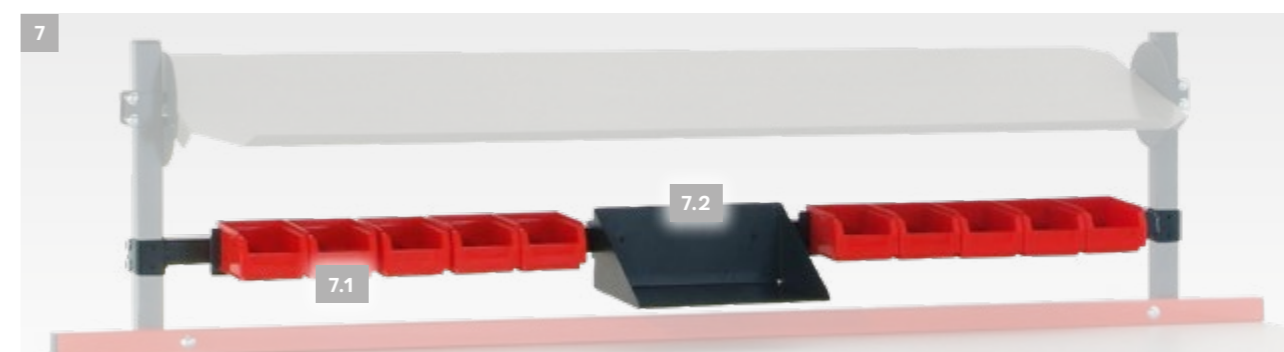



8 Cupboard unit

with 1 drawer and 1 cupboard door, changeable cupboard door for right/left hinges, interior cupboard dimensions W 490 x D 570 x H 430 mm, interior drawer dimensions W 430 x D 550 x H 180 mm

separately lockable

Art. 2011 W 535 x D 600 x H 785 mm, weight 45 kg



9 Drawer unit

with 3 drawers, retraction 420 mm, max. surface load per drawer 25 kg, Interior dimensions W 430 x D 550 x H 180 mm

central locking mechanism

Art. 2010 W 535 x D 600 x H 785 mm, weight 45 kg



10 Steel container mobile

with 4 castors, with plastic insert for waste disposal

max. surface load 30 kg

Art. 200800 W 500 x D 650 x H 525 mm, weight 18 kg



11 Double drawer

separately lockable, can be used on the right and/or left under the table, telescopic guide rails, interior dimensions W 460 x D 495 x H 120 mm

max. surface load per drawer 20 kg

Art. 200620 W 520 x D 500 x H 320 mm, weight 16 kg

12 Steel drawer

lockable, can be used on the right and/or left under the table, plastic guide rail, interior dimensions W 520 x D 500 x H 150 mm, max. surface load 35 kg

with safety catch to prevent slipping out

Art. 200600 W 520 x D 500 x H 150 mm, weight 9 kg



Further cutting systems page 124

13 Undertable storage rack, mobile with telescopic handle

4 castors, 2 of which are lockable, max. surface load 100 kg

- Art. 2042-1 W 1,015 x D 600 x H 690 mm, one level for approx. 100 folding cartons, weight 23 kg
 Art. 2043-1 W 1,600 x D 600 x H 690 mm, one level for approx. 160 folding cartons, weight 31 kg



14 Undertable storage rack, mobile

4 castors, 2 of which are lockable, max. surface load 100 kg

- Art. 2042 W 1,015 x D 600 x H 604 mm, one level for approx. 100 folding cartons, weight 21 kg
 Art. 2043 W 1,600 x D 600 x H 604 mm, one level for approx. 160 folding cartons, weight 27 kg



15 Spindle between the uprights

spindle tube Ø 32 mm, without cones and clamp rings

max. roll weight 50 kg

- Art. 23816 W 1,620 x Ø 32 mm, weight 2.2 kg
 Art. 62/11 Cones with clamp rings (1 set) for core diameter 60-85 mm, weight 0.8 kg
 Art. 62/12 Cones with clamp rings (1 set) for core diameter 135-155 mm, weight 1.1 kg



16 Spindle set, under-table

Spindle tube Ø 32 mm, 1 pair of cones and clamp rings for adjusting the roll and spindle, cones for core diameter 60 - 85 mm

max. roll weight 100 kg

- Art. 23900 W 1,835 x Ø 32 mm, weight 4 kg, for table width 2,000 mm, max. roll width 1,600 mm
 Art. 23910 W 1,000 x Ø 32 mm, weight 4 kg, for table width 1,600 mm, max. roll width 1,000 mm
 Art. 23800 Bearing shells for roll spindle, horizontal weight 1 kg



17 Under-table cutter stand, mobile

dispensing height 580 mm, 4 castors, 2 of which are lockable, max. roll weight 200 kg

max. roll Ø 750 mm

- Art. 25507 W 1,000 x D 880 x H 740 mm, cutting width 750 mm, weight 23 kg
 Art. 25510 W 1,250 x D 880 x H 740 mm, cutting width 1,000 mm, weight 26 kg
 Art. 25512 W 1,500 x D 880 x H 740 mm, cutting width 1,250 mm, weight 28 kg
 Art. 25516 W 1,850 x D 880 x H 740 mm, cutting width 1,600 mm, weight 32 kg

18 Mobile roll dispenser

4 castors, 2 of which are lockable, max. roll width 750 mm, max. roll weight 200 kg

max. roll Ø 500 mm

- Art. 23107 W 1,000 x D 880 x H 740 mm, weight 13 kg
 Art. 23110 W 1,250 x D 880 x H 740 mm, weight 15 kg
 Art. 23112 W 1,500 x D 880 x H 740 mm, weight 17 kg



19 Add-on cutter

clamping range up to 70 mm, suitable for 203000 and 503000

incl. 2 cutter cartridges

- Art. 55107 cutting width 750 mm, weight 9.4 kg
 Art. 55110 cutting width 1,000 mm, weight 11 kg
 Art. 55112 cutting width 1,250 mm, weight 12.4 kg

20 Castor set

for height-adjustable packing tables, 4 castors, 2 with brake function

- Art. 2030-2 Ø 125 mm, height 162 mm, weight 3.8 kg
 Art. 203502 Ø 50 mm (Dual role), height 69 mm, weight 3.8 kg

Further cutting systems page 124

SYSTEM BASIC

The revised SYSTEM BASIC is the inexpensive entry into the world of packaging. Limited to the essential functions, SYSTEM BASIC offers good value for money in the usual high Rocholz quality.



This packing table system is the solution for areas of application in which every Euro is important and where high-quality requirements need to be met at the same time. Expandable with practical accessories, this universally adaptable table offers everything you need to cover your needs sensibly, and keep costs low.

- sturdy table in steel construction with integrated bearing shells for holding a material roll shaft
- working height 850 mm, with level compensation
- 19 mm melamine resin-coated table top
- max. surface load 100 kg
- shelves made of galvanised sheet steel
- cutter with titanium-coated blade
- IT accessories for PC, monitor and keyboard
- powder-coated steel parts: gentian blue RAL 5010

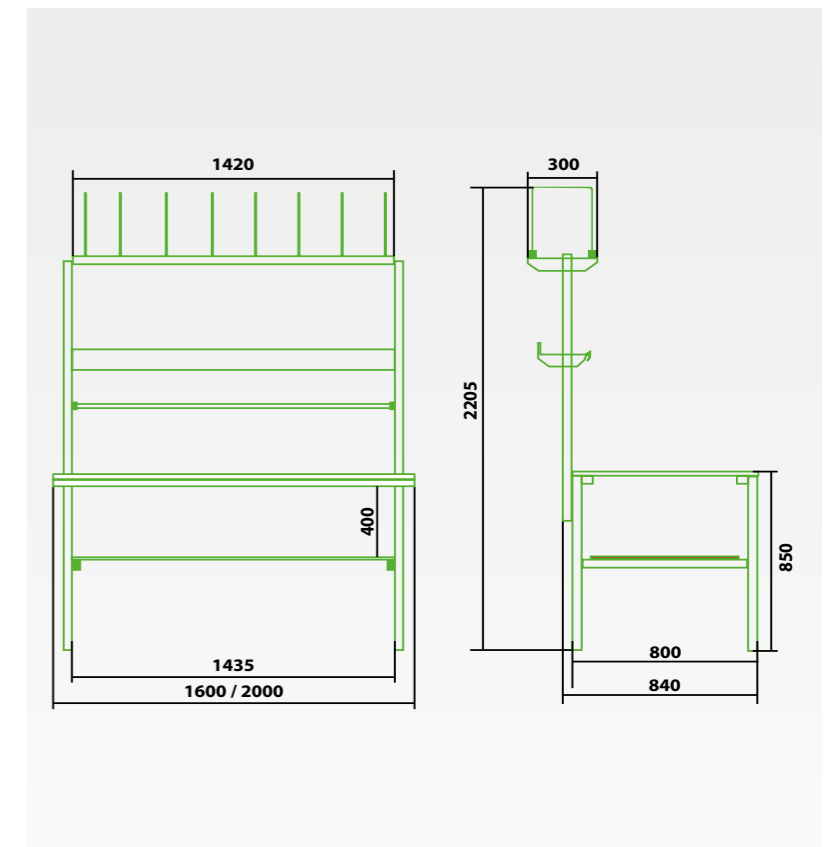



1 SYSTEM BASIC complete packing station model 1

incl. add-on storage rack with 8 dividers, spindle between the uprights for holding paper and film rolls (max. roll diameter 300 mm, max. roll weight 20 kg)

incl. document shelf D 230 mm

Art. 701600 W 1,600x D 800 x H 850 mm, weight 81 kg
 Art. 702000 W 2,000x D 800 x H 850 mm, weight 85 kg

2 SYSTEM BASIC complete packing station model 2

incl. add-on storage rack with 8 dividers, spindle between the uprights for holding paper and film rolls (max. roll diameter 300 mm, max. roll weight 20 kg), document shelf D 230 mm, spindle under the table for paper or film (max. roll diameter 750 mm, max. roll weight 100 kg)

incl. cutter between the uprights with a cutting width of 1,250 mm

Art. 711600 W 1,600x D 800 x H 850 mm, weight 67 kg
 Art. 712000 W 2,000x D 800 x H 850 mm, weight 74 kg

3 SYSTEM BASIC complete packing station model 3

incl. add-on storage rack with 8 dividers, spindle between the uprights for holding paper and film rolls (max. roll diameter 300 mm, max. roll weight 20 kg), document shelf D 230 mm

incl. bottom shelf under the table top

Art. 721600 W 1,600x D 800 x H 850 mm, weight 81 kg
 Art. 722000 W 2,000x D 800 x H 850 mm, weight 109 kg

4 Document shelf

galvanised sheet steel for attachment between the uprights

max. surface load 50 kg

Art. 700060 W 1,425 x D 253 x H 114 mm, weight 6 kg

5 Spindle under the table

max. roll weight 100 kg

for holding rolls max. roll diameter 750 mm

Art. 700150 W 1,430 mm, weight 2.1 kg

6 Container

mobile metal frame with 4 castors, 2 of which have brakes, incl. sturdy plastic container

max. surface load 50 kg

Art. 700110 W 610 x D 416 x H 495 mm, weight 7 kg





7 SYSTEM BASIC packing and work table

sturdy steel construction, struts and legs made of square tubing, 19 mm melamine resin-coated table top

max. surface load 100 kg

Art. 700001 W 1,600 x D 800 x H 850 mm, weight 34 kg
 Art. 700002 W 2,000 x D 800 x H 850 mm, weight 41 kg

8 Uprights

for attaching table accessories to the uprights, height above table 1,032 mm, 1 sales unit = 2 pcs.

Art. 700030 W 40 x D 40 H 1,266 mm, weight 9 kg

9 Add-on storage rack

square tubing, for attachment to the uprights, incl. 8 galvanised dividers

max. surface load 50 kg

Art. 700050 W 1,435 x D 300 x H 400 mm, weight 19 kg

10 Storage shelf

galvanised sheet steel for attachment to the uprights

max. surface load 25 kg

Art. 700070 W 1,430 x D 400 x H 58 mm, weight 15 kg

11 Spindle between the uprights

max. roll weight 20 kg

for holding rolls max. Ø 300 mm

Art. 700140 W 1,425 mm, weight 0.5 kg

12 Add-on cutter

galvanised, for attachment to the uprights, incl. spindle

cutting width 1,250 mm

Art. 700090 W 1,500 x D 157 x H 183 mm, weight 12 kg

13 Under-table carton storage rack

square tubing, mobile with 4 castors, 2 of which have brakes, incl. 8 dividers

max. surface load 50 kg

Art. 700080 W 1,415 x D 300 x H 415 mm, weight 14 kg

14 Side table

square tubing, table top made of galvanised sheet steel

max. surface load 100 kg

Art. 700020 W 600 x D 600 x H 750 mm, weight 20 kg



Further cutting systems page 124



15 Cutter stand

horizontal, incl. exchangeable cartridge with blade for foam, bubble wrap, paper etc., without cones and clamp rings, max. roll weight 50 kg, max. roll diameter 1.000 mm
cutting width 1,250 mm

- Art. 700130 W 1,500 x D 975 x H 1,100 mm, weight 24 kg
- Art. 62/11 cones with clamp rings (1 set) for core diameter 60-85 mm, weight 0.8 kg
- Art. 62/12 cones with clamp rings (1 set) for core diameter 135-155 mm, weight 1.1 kg

16 Drawer

sheet steel drawer, interior dimensions W 460 x D 525 x H 100 mm, lockable

max. surface load 12.5 kg

- Art. 700120 W 513 x D 530 x H 160 mm, weight 9 kg

17 Bottom shelf

19 mm melamine resin-coated board

max. surface load 50 kg

- Art. 700100 W 1,525 x D 650 x H 19 mm, weight 19 kg



18 Monitor holder, Vesa 75/100

for attachment to the uprights, incl. adapter for Vesa 75/100
can be positioned at any height with clamp fastening

- Art. 228120 W 200 x D 100 x H 100 mm, weight 1.8 kg

19 PC holder with strap

for attachment under the table top, max. surface load 20 kg
infinitely adjustable to any size

- Art. 308100 Circumference max. 1,680 mm, weight 1 kg

20 Backboard

galvanised sheet steel, for attachment to the uprights

- Art. 700040 W 1,515 x D 4 x H 70 mm, weight 1.2 kg



Further IT accessories from page 110

MODUL 5000

The design is exceptional, ergonomic and has won international awards. Thanks to its intelligent design, MODUL 5000 can be adapted to users and their work processes in just a few simple steps. The working level can also be adjusted with a crank or very conveniently via electrical motor.



Overview of special features:

- modular structure
- height adjustment via crank or convenient electrical adjustment
- internationally recognised (iF Design Award)
- exceptional and ergonomic design
- extensive range of accessories

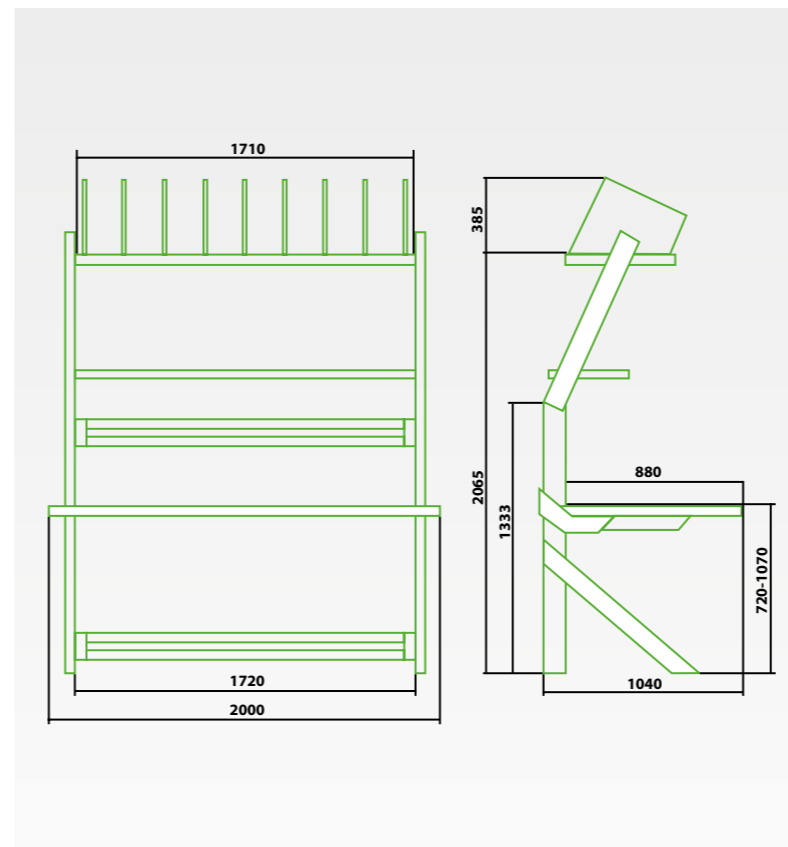
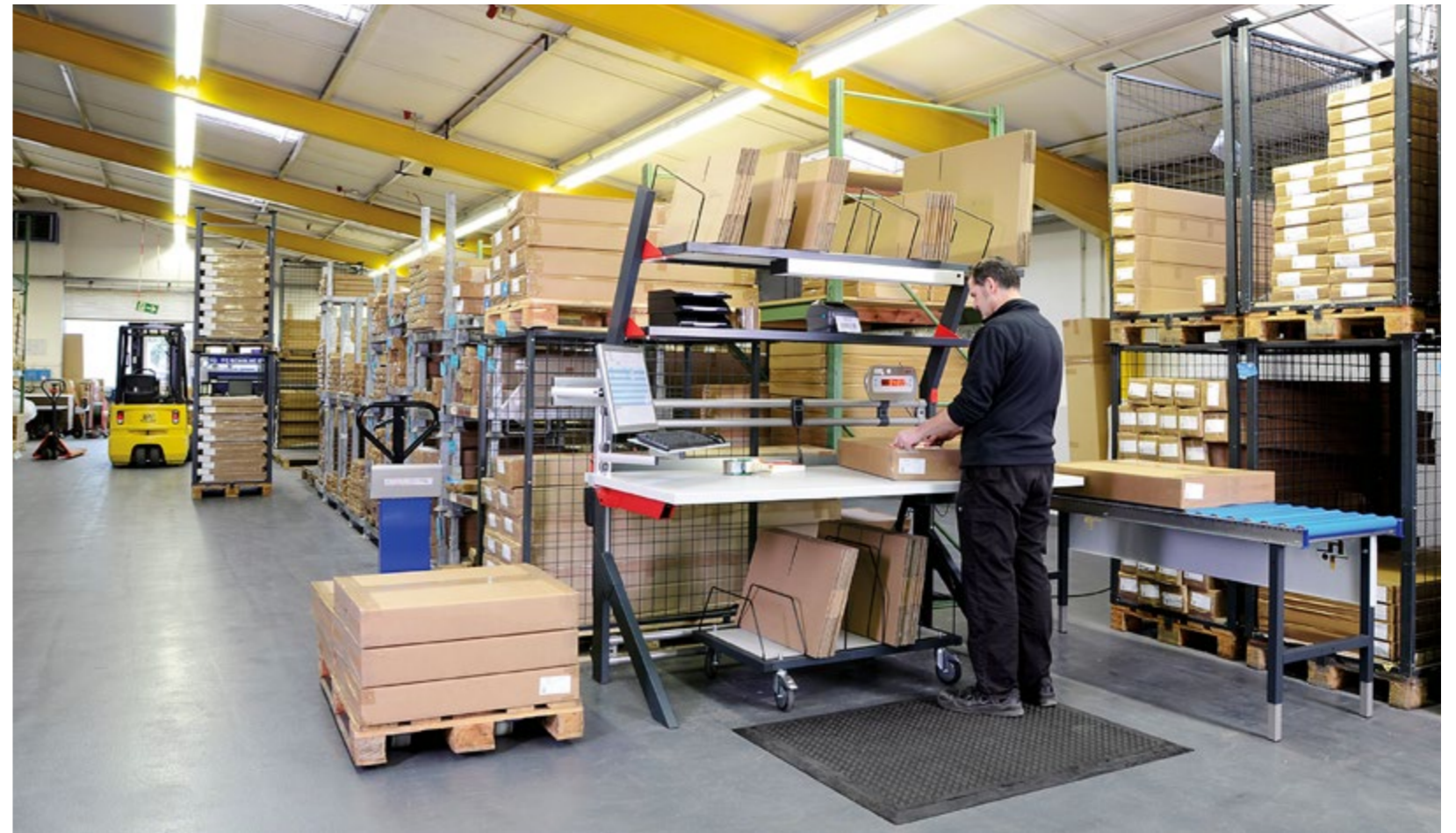

Integrated roller track

One highlight is the MODUL 5000 packing table with integrated roller track. There is enough space on the galvanised sheet steel work surface to „fix“ even larger packages. The table is height-adjustable from 770 - 1120 mm. This allows easy integration into your picking and packing processes.

1 MODUL 5000 packing and work table

sturdy welded construction, base frame and table support arms made of tubular steel (100 x 40 mm), table top W 2,000 x D 880 x H 38 mm, light grey plastic-coated with anti-glare surface and rounded edges, max. surface load 200 kg

height-adjustable from 720-1,070 mm

Art. 503000	W 2,000 x D 1,040 x H 1,330 mm, weight 90 kg, height-adjustable in 50 mm increments
Art. 503500	W 2,000 x D 1,040 x H 1,330 mm, weight 100 kg, infinitely height-adjustable via insertable crank
Art. 503800	W 2,000 x D 1,040 x H 1,330 mm, weight 120 kg, infinitely electrically height-adjustable, with cable duct, max. surface load with adjustment 100 kg, electrical connection 230 V, 50 Hz, max. lifting speed 12 mm/sec



2 MODUL 5000 Packing and work table with scale

sturdy welded construction, table top W 2,000 x D 880 x H 38 mm, with integrated calibratable digital package scale up to 60 kg, scale division 20 g, EDP interface, stainless steel platform, height-adjustable from 720-1,070 mm, max. surface load 200 kg

with separate display unit

Art. 503042	W 2,000 x D 1,040 x H 1,330 mm, weight 110 kg, height-adjustable in 50 mm increments
Art. 503552	W 2,000 x D 1,040 x H 1,330 mm, weight 130 kg, infinitely height-adjustable via insertable crank
Art. 503852	W 2,000 x D 1,040 x H 1,330 mm, weight 130 kg, infinitely electrically height-adjustable, with cable duct, max. surface load with adjustment 100 kg, electrical connection 230 V, 50 Hz, max. lifting speed 12 mm/sec

3 Uprights

with perforated grid for attaching various shelves at different levels, 1 sales unit = 2 pcs.

for attaching the upper table elements

Art. 5064	W 40 x D 95 x H 950 mm, weight 8 kg
-----------	-------------------------------------

4 Backboard

simple clamp attachment to the rear edge, light grey plastic-coated

for rear confinement of the table surface

Art. 5060	W 1,705 x D 38 x H 85 mm, weight 4 kg
-----------	---------------------------------------

5 Cable duct

with screw-mounted cover, only for table 503000

flexible plastic cable guide

Art. 5075	W 1,680 x D 155 x H 185 mm, weight 13 kg
-----------	--

6 Drawer

can be used on the right or left under the table, plastic guide rail with safety catch to prevent slipping out, max. surface load 20 kg

lockable

Art. 5006	W 475 x D 570 x H 100 mm, weight 8 kg
-----------	---------------------------------------

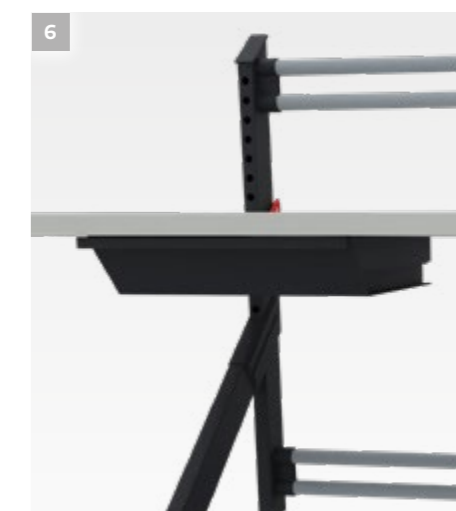



1 MODUL 5000 roller track table with work surface

packing table with integrated roller track, roller width 600 mm, division 75 mm, diameter 50 mm, sturdy welded construction, base frame and table support arms made of tubular steel (100 x 40 mm), work surface made of galvanised sheet steel
height-adjustable from 770-1,120 mm

Art. 503010	W 1,955 x D 1,040 x H 1,330 mm, weight 87 kg, work surface W 2,000 x D 251 mm, height-adjustable in 50 mm increments
Art. 503510	W 1,955 x D 1,040 x H 1,330 mm, weight 98 kg, work surface W 2,000 x D 265 mm, infinitely height-adjustable via insertable crank
Art. 503810	W 1,955 x D 1,040 x H 1,330 mm, weight 99 kg, worktop W 2,000 x D 265 mm, electrically height-adjustable, with cable duct, max. surface load with adjustment 100 kg, electrical connection 230 V, 50 Hz, max. lifting speed 12 mm/sec



2 MODUL 5000 roller track table with work surface and integrated scale

with integrated calibrated digital package scale up to 60 kg, supplied with interface cable, work surface W 1,955 x D 251 mm made of galvanised sheet steel, roller width 600 mm, division 75 mm, diameter 50 mm, rear side guide, sturdy welded construction, base frame and table support arms made of tubular steel (100 x 40 mm), height-adjustable from 770-1,120 mm
with separate display unit

Art. 503012	W 1,955 x D 1,040 x H 1,330 mm, weight 118 kg, height-adjustable in 50 mm increments
Art. 503512	W 1,955 x D 1,040 x H 1,330 mm, weight 129 kg, infinitely height-adjustable via insertable crank
Art. 503812	W 1,955 x D 1,040 x H 1,330 mm, weight 130 kg, infinitely electrically height-adjustable, with cable duct, max. surface load with adjustment 100 kg, electrical connection 230 V, 50 Hz, max. lifting speed 12 mm/sec

3 Side guard for roller track tables

limiter for safely guiding packages and parcels on the roller track

Art. 203540	W 1,955 x D 20 x H 70 mm, weight 3 kg
-------------	---------------------------------------

4 End stop for roller track tables

limiter for packages and parcels on the roller track (only in the area of the roller track)

Art. 203541	W 600 x D 10 x H 100 mm, weight 2.9 kg
-------------	--

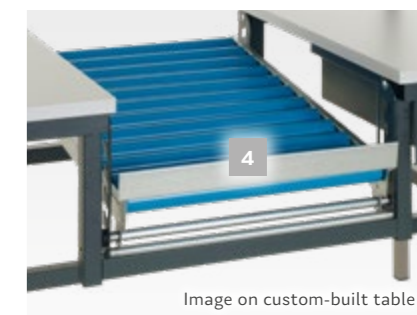
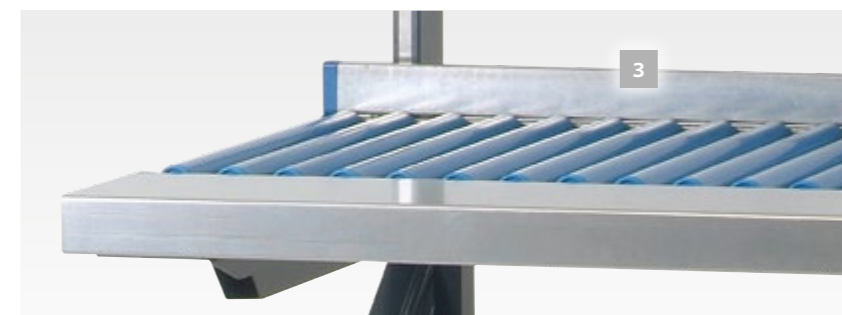

Image on custom-built table

1 Storage rack with dividers

with 9 steel dividers, for attachment at varying heights in the perforations of the top uprights, max. surface load 100 kg
storage space for approx. 160 folding cartons

Art. 505300 W 1,705 x D 550 x H 40 mm, weight 28 kg

2 Storage shelf

for attachment in the perforations in the top uprights, steel frame with shelf, max. surface load 70 kg
for packing materials, forms etc.

Art. 505000 W 1,705 x D 400 mm, weight 18 kg

3 Multi-purpose tray

max. surface load 15 kg
for mounting on tubular cross members

Art. 5081 W 315 x D 240 x H 130 mm, weight 3 kg



4 Undertable storage rack mobile short

mobile and lockable, 6 steel wire dividers, max. surface load 50 kg
storage space for approx. 100 folding cartons

Art. 5042 W 1,110 x D 550 x H 480 mm, weight 20 kg

5 Undertable storage rack mobile long

mobile and lockable, 9 steel wire dividers, max. surface load 50 kg
storage space for approx. 160 folding cartons

Art. 5043 W 1,705 x D 550 x H 480 mm, weight 32 kg

6 Storage shelf

max. surface load 50 kg
for mounting on tubular cross members

Art. 5051 W 1,705 x D 295 mm, weight 17 kg

7 Bottom shelf mobile

4 castors, 2 with brakes
max. surface load 50 kg

Art. 5009 W 1,600 x D 700 x H 100 mm, weight 29 kg

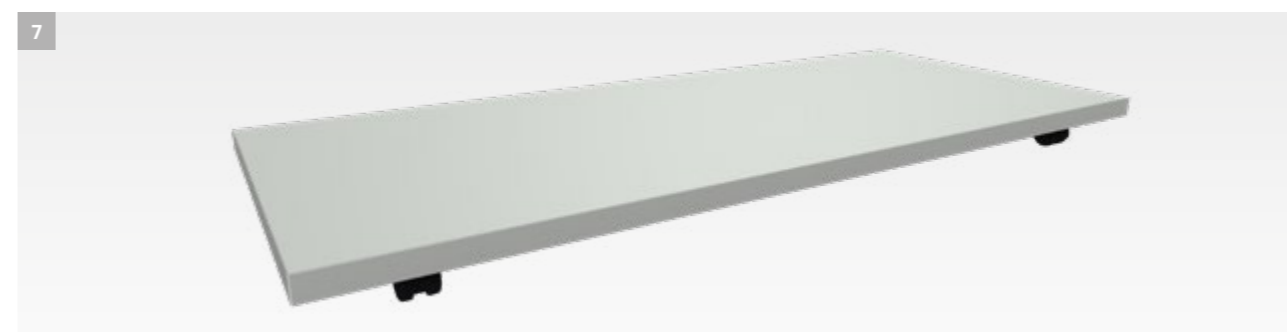

1 Keyboard and mouse platform with folding arm

for flexible mounting in the system grooves of the Rocholz mounting profiles with perforation, support column (509001, 509002, 509006), profile rail (509005) or upright adapter (509003), platform 640 x 172 mm, tiltable up to 25°, rotatable and swivelling, reach 728 mm

max. surface load 10 kg

Art. 509201 W 640 x D 728 x H 120 mm, weight 3.5 kg

2 Notebook tray with folding arm

for flexible mounting in the system grooves of Rocholz mounting profiles with perforation, support column (509001, 509002, 509006), profile rail (509005) or upright adapter (509003), cable opening in the platform, reach 589 mm

max. surface load 10 kg

Art. 509213 W 404 x D 589 x H 120 mm, tray W 404 x D 288 mm, weight 1.5 kg

3 Retractable keyboard tray

extendable mouse tray can be pulled out to the left or right, under-table mounting, interior dimensions keyboard tray W 527 x D 250 mm, RAL 9006 white aluminium

minimum tabletop thickness 25 mm

Art. 509318 W 577 x D 290 x H 119 mm, weight 4.1 kg



Image on SYSTEM FLEX



Image of under-table mounting on SYSTEM FLEX



4

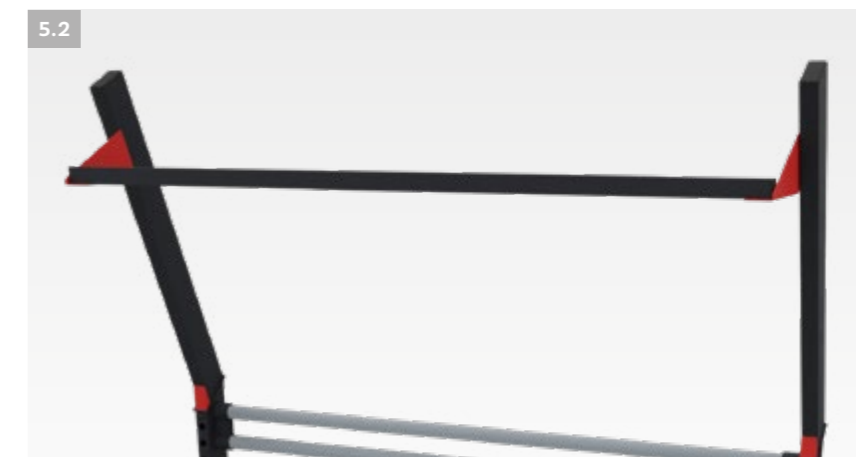

5.2



5.1

Image on SYSTEM FLEX

4 Monitor tray

attachment to storage shelf 5050/5051 or to multi-purpose tray 5081

adjustable inclined shelf with non-slip rubber pad for keyboard

Art. 5085 W 420 x D 570 mm, weight 7 kg

5 Workplace lighting

sturdy aluminium casing, for mounting under the storage rack with dividers (505300) on the holder (507001), 4,000 K, 0.15 A, protection class IP30, incl. 4 m connection cable

can be adjusted to lighting requirements with dimming function

5.1 Art. 207003 W 976 x D 51 x H 54 mm, 32 W, 3368 lm, weight 1.8 kg

5.1 Art. 207004 W 661 x D 51 x H 54 mm, 21 W, 2158 lm, weight 1.5 kg

5.2 Art. 507001 W 1,720 x D 40 x H 40 mm, weight 5.6 kg, holder for mounting the workplace lighting

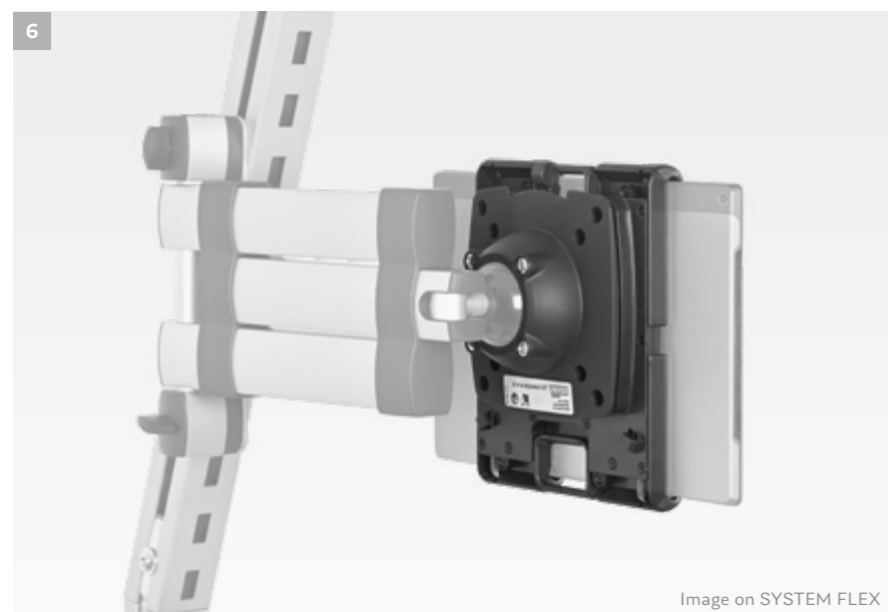

6 Tablet holder

for attaching to monitor folding arms (support arm not included), VESA 75/100 quick-release attachment, clamping length 160-300 mm for tablets from 7" to 10"

Art. 509214 weight 0.5 kg

7 Monitor support carriage

for flexible attachment of a monitor to the support column, profile rail, in the system groove of the Rocholz profiles with perforation or on the upright adapter (509003) max. load capacity 12 kg

Art. 509202 W 100 x D 125 H 115 mm, weight 1 kg

8 Support column with screw clamp

aluminium profile with clamp attachment

for attaching a monitor folding arm and a keyboard tray

- Art. 509001 W 51 x D 51 x H 445 mm, weight 1.5 kg, clamping range 14-40 mm
- Art. 509002 W 51 x D 51 x H 445 mm, weight 2 kg, clamping range 5-70 mm
- Art. 509006 W 51 x D 51 x H 845 mm, weight 2.7 kg, clamping range 5-65 mm

9 4-socket outlet

clamp mounting on the uprights, power connection 230 V, 16 A incl. 3 m power supply cable

Art. 2074 W 61 x D 45 x H 304 mm, weight 1 kg

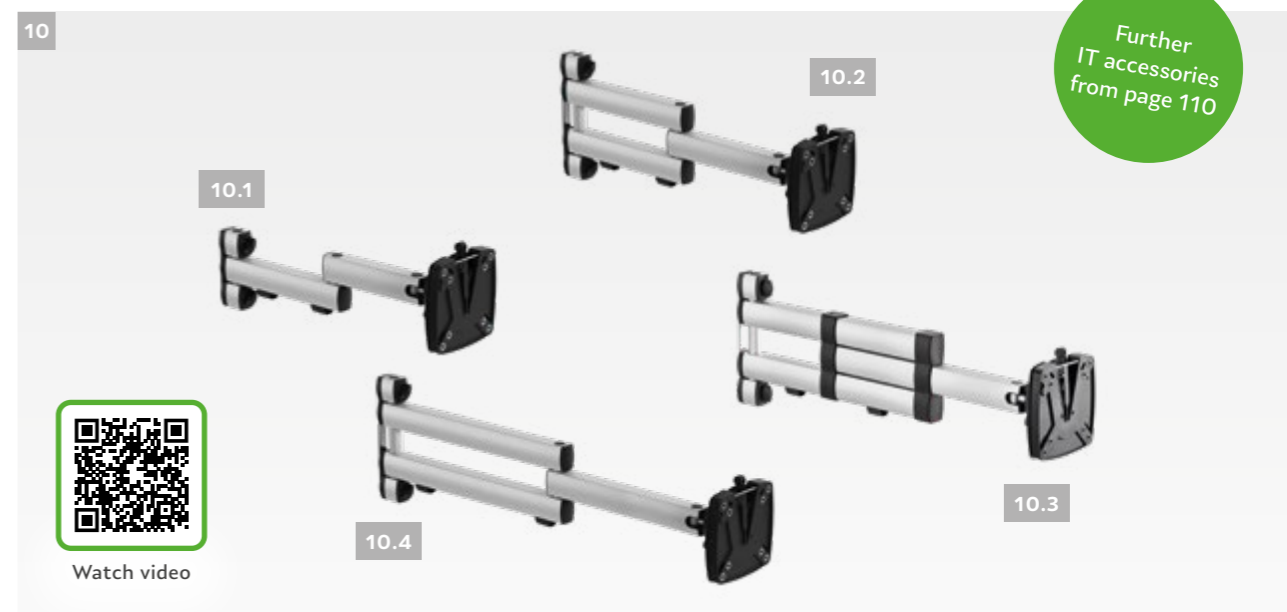

10 Monitor folding arm

for flexible mounting of a monitor in the system groove of Rocholz profiles with perforation, support column (509001, 509002, 509006), profile rail (509005) or upright adapter (509003), incl. cable holder VESA 75/100 quick-release attachment

- | | | |
|------|-------------|--|
| 10.1 | Art. 509203 | W 100 x D 450 x H 120 mm, weight 2 kg, max. load capacity 10 kg |
| 10.2 | Art. 509204 | W 100 x D 505 x H 200 mm, weight 2.1 kg, max. load capacity 15 kg |
| 10.3 | Art. 509207 | W 100 x D 456-704 x H 200 mm, weight 2.5 kg, max. load capacity 8 kg |
| 10.4 | Art. 509209 | W 100 x D 700 x H 200 mm, weight 2.5 kg, max. load capacity 10 kg |

11 Holder for scale display unit

for mounting on tubular cross members

Art. 5091 W 120 x D 92 x H 42 mm, weight 1.2 kg



12 Add-on cutter

clamping range up to 70 mm, suitable for 203000 and 503000

incl. 2 cutter cartridges

- Art. 55107 cutting width 750 mm, weight 9.4 kg
- Art. 55110 cutting width 1,000 mm, weight 11 kg
- Art. 55112 cutting width 1,250 mm, weight 12.4 kg



SYSTEM UP

Aim high with our standing workstations! MODUL 5100 and 5200 are now the new SYSTEM UP.

As a standing workstation in production departments, warehouses and also offices, SYSTEM UP cuts a fine figure as a space-saving, functional stationary solution. SYSTEM UP is also versatile as a mobile version and can be used as a QM station, workshop trolley or mobile information stand.



Put together your SYSTEM UP according to your individual needs: we also supply the matching standing aid.

The mobile version is equipped with four castors (two of which have brakes).



Watch video

1 Mobile packing station

metal shelf and storage rack consisting of base frame (532065), castors (23601), metal shelf max. surface load 25 kg (526064S), storage rack with 6 dividers max. surface load 25 kg (527108), wooden board max. surface load 50 kg (527106G)

narrow and two-sided

Art. 531010N
Art. 527109

W 1,050 x D 1,060 x H 1,800 mm, weight 71 kg
VESA 75/100 holder for monitor, W 610 x H 282 mm, max. load capacity 30 kg, weight 1.5 kg



Image contains accessories



Ergonomic accessories from page 108



Image contains accessories



Image contains accessories

6 Mobile QM station for folders

with information board, perforated back panel, metal shelf (max. surface load 50 kg), cabinet for folders (max. surface load 35 kg)
metal shelf and cabinet for folders

Art. 531005 W 670 x D 650 x H 1,765 mm, weight 46 kg

7 Mobile, wide QM station with drawer

with information board, perforated back panel, metal shelf (max. surface load 50 kg), drawer (max. surface load 35 kg, useable height 125 mm)
metal shelf and drawer for small utensils

Art. 531007 W 1,050 x D 650 x H 1,765 mm, weight 65 kg

2 Mobile standing/sitting workplace

standing desk height adjustment in 50 mm increments (max. surface load 200 kg), storage shelf top W 535 x D 350 x H 38 mm (max. load 200 kg), surface load 50 kg), drawer lockable W 475 x D 570 x H 100 mm (max. load 50 kg), surface load 20 kg), storage shelf bottom W 650 x D 400 x H 38 mm (max. surface load 50 kg), multi-purpose shelf W 315 x D 240 x H 130 mm (max. surface load 15 kg), 4 castors, 2 with brakes

Art. 510010 W 800 x D 750 x H 1,330 mm, weight 85 kg

3 ErgoPlus 3000 standing aid

incl. foot rest, foldable, max. height surface load 110 kg
 infinite adjustment of the backrest and seat cushion from 600-900 mm

Art. 519192 W 670 x D 500 x H 1,100 mm, weight 12 kg

4 Mobile QM station with drawer

with information board, perforated back panel, metal shelf (max. surface load 50 kg), drawer (max. surface load 35 kg, useable height 130 mm)
metal shelf and drawer for small utensils

Art. 531003 W 670 x D 650 x H 1,765 mm, weight 53 kg

5 Mobile QM station for hanging files

with information board, perforated back panel, metal shelf (max. surface load 50 kg), drawer (max. surface load 35 kg)
large drawer for hanging files

Art. 531004 W 670 x D 650 x H 1,765 mm, weight 53 kg



Image contains accessories



Image contains accessories

ESD ACCESSORIES

ESD (electrostatic discharge) is a form of discharge that can occur due to different voltages in all kinds of daily situations. This kind of discharge can cause damage to electronic parts that is often not even recognisable. Therefore, we offer conductive worktops and ESD accessories for picking and packaging sensitive electronic components, which prevent damage by means of said conductivity.

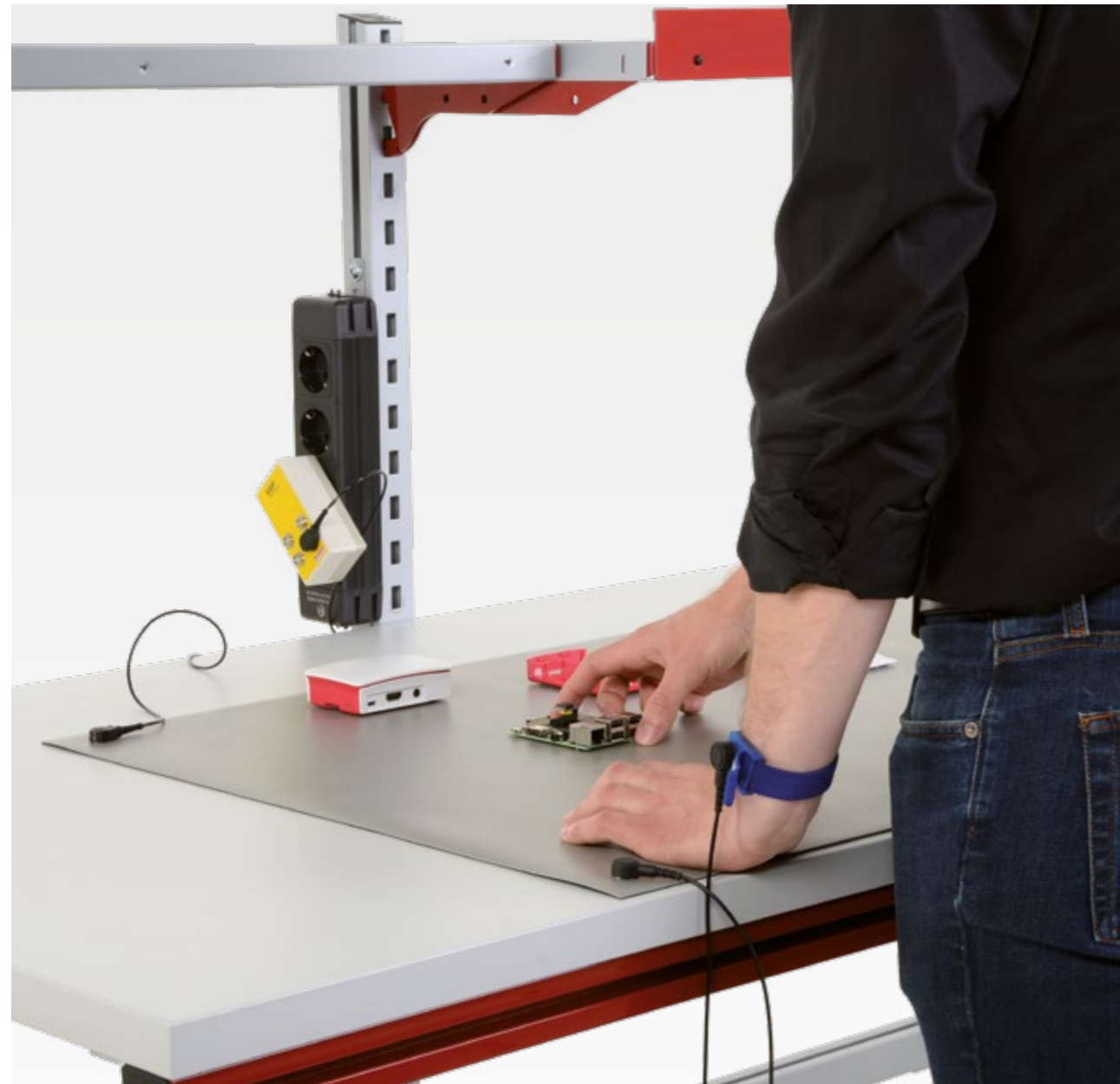

1 Ergonomic workplace mat

ESD dry, black, consisting of two puzzle pieces, flat textured surface, bevelled edges for reduced risk of tripping, anti-slip surface, incl. connection set, fire protection class Bfl-s

gentle on joints and intervertebral discs (AGR seal of approval)

Art. 86000101 W 1,950 x D 1,000 x H 16 mm, weight 22 kg

2 Wrist strap set

consisting of wrist strap and 10 mm snap + spiral cable, length 2 m, 10 mm - 10 mm snap

Art. 99090242 weight 0.05 kg

3 ESD workplace set

grey table mat with 2 snap connectors (W 1,000 x D 600 x H 10 mm), wrist strap with snap (3 mm), spiral cable (3 mm, 2 m long + 10 mm snap), EBP box (shockproof grounding plug) with 2 x 10 mm snaps + 1 x safety socket, connecting cable table mat-EBP box, identification label

Art. 86000130 weight 2.1 kg

4 Grounding module EB 7118 SC

with 3 safety resistors, 1 M Ohm and 3 snap connectors for grounding via shockproof grounding socket, ESD connecting cable VL 7127 SC, 1.5 m grounding cable, incl. green/yellow ground straps

ATTENTION: Grounding module for vertical cutter stands (Art. 554) is not suitable for your own retrofitting, and must be installed on Rocholz premises!

Art. 550 for cutter stands 55..., 1x ground strap 250 mm, weight 0.1 kg

Art. 551 for cutter stand 262..., 1x ground strap 250 mm, 1x ground strap 650 mm, weight 0.14 kg

Art. 552 for cutter stand 264..., 2x ground strap 250 mm, 2x ground strap 400 mm, weight 0.21 kg

Art. 553 for double cutter stands 554..., 2x ground strap 250 mm, 1x ground strap 650 mm, weight 0.18 kg

Art. 554 for vertical cutter stands, Article not suitable for your own retrofitting!

DOCUMENTABLE

- ✓ Integrated photo documentation of package contents
- ✓ Distinct classification of stored data

- ✓ Transmission via LAN into your own server structure, connection to your own ERP system possible
- ✓ All-in-one solution without follow-up costs

A maintenance service can be booked for all assistance and documentation systems. We are happy to talk to you about your individual requirements to find the right solution for you.



DocumenTable enables you to take photos for documentation right at your logistics table in your dispatch or incoming goods department. The first step is to scan the delivery note number with the integrated scanner; this activates the system. As soon as the packet (or one layer in the packet) is readily packed, you can trigger the camera by operating the push button. The images are automatically named with the delivery note number and a date and time stamp (exact to the second); this assigns them distinctly and uniquely. The generated data is saved

to the integrated storage (standard: 25 GB) and can be retrieved over the network. An integrated and clearly visible LED strip shows the system status at all times. Other distinct indicators for scanning, such as order number, packet number or customer number, can also be used as identifiers for images. The corresponding shelf for SYSTEM FLEX is fully equipped, readily installed and merely needs to be connected to your power supply and IT-network. Depending on the application, the system can be operated over a (wireless) scanner instead of over the push button.



Watch video

1 DocumenTable 2.0

- | | |
|---------------|---|
| Art. 73802100 | DocumenTable camera left, ruby red, W 800 x D 400 mm, weight 10.4 kg |
| Art. 73802300 | DocumenTable camera right, ruby red, W 800 x D 400 mm, weight 10.4 kg |
| Art. 73802200 | DocumenTable camera left, ruby red, W 1,000 x D 400 mm, weight 11.6 kg |
| Art. 73802400 | DocumenTable camera right, ruby red, W 1,000 x D 400 mm, weight 11.6 kg |
| Art. 73802101 | DocumenTable camera left, gentian blue, W 800 x D 400 mm, weight 10.4 kg |
| Art. 73802301 | DocumenTable camera right, gentian blue, W 800 x D 400 mm, weight 10.4 kg |
| Art. 73802201 | DocumenTable camera left, gentian blue, W 1,000 x D 400 mm, weight 11.6 kg |
| Art. 73802401 | DocumenTable camera right, gentian blue, W 1,000 x D 400 mm, weight 11.6 kg |

2 DocumenTable Box

- | | |
|---------------|---|
| Art. 73800000 | DocumenTable Box, W 300 x D 250 x H 76 mm, weight 4.25 kg |
|---------------|---|

ASSISTABLE

- ✓ Simple implementation of value-added services
- ✓ Self-determined work in spite of product individualisation and wide variety
- ✓ Server-based system that can be operated location-independently
- ✓ Automatic generation of economic indicators via digitalisation



Watch video

AssisTable is a digital work catalogue that supports users in picking and packing processes. Depending on the supplier, destination country and/or certain item properties, there are certain specifications as to how the item is to be packed or processed, and which documents are to be added. The individual steps are shown in short form (if necessary, in detail) and with images. At the same time, an integrated quality report

records the executed activities and quantities. In this way, data is generated that can be used, for instance, for a billing model or for forward-looking capacity planning. The user-friendly interface ensures that the system can be used and work catalogues can be generated or updated after a short period of familiarisation and without broad IT-knowledge.

INSPECTABLE

- ✓ Zero errors due to optical monitoring
- ✓ Flexible system that is easy to train for the intended application
- ✓ Representation of different conditions and indicators for hit probability
- ✓ Intelligent system that learns independently through continuous use

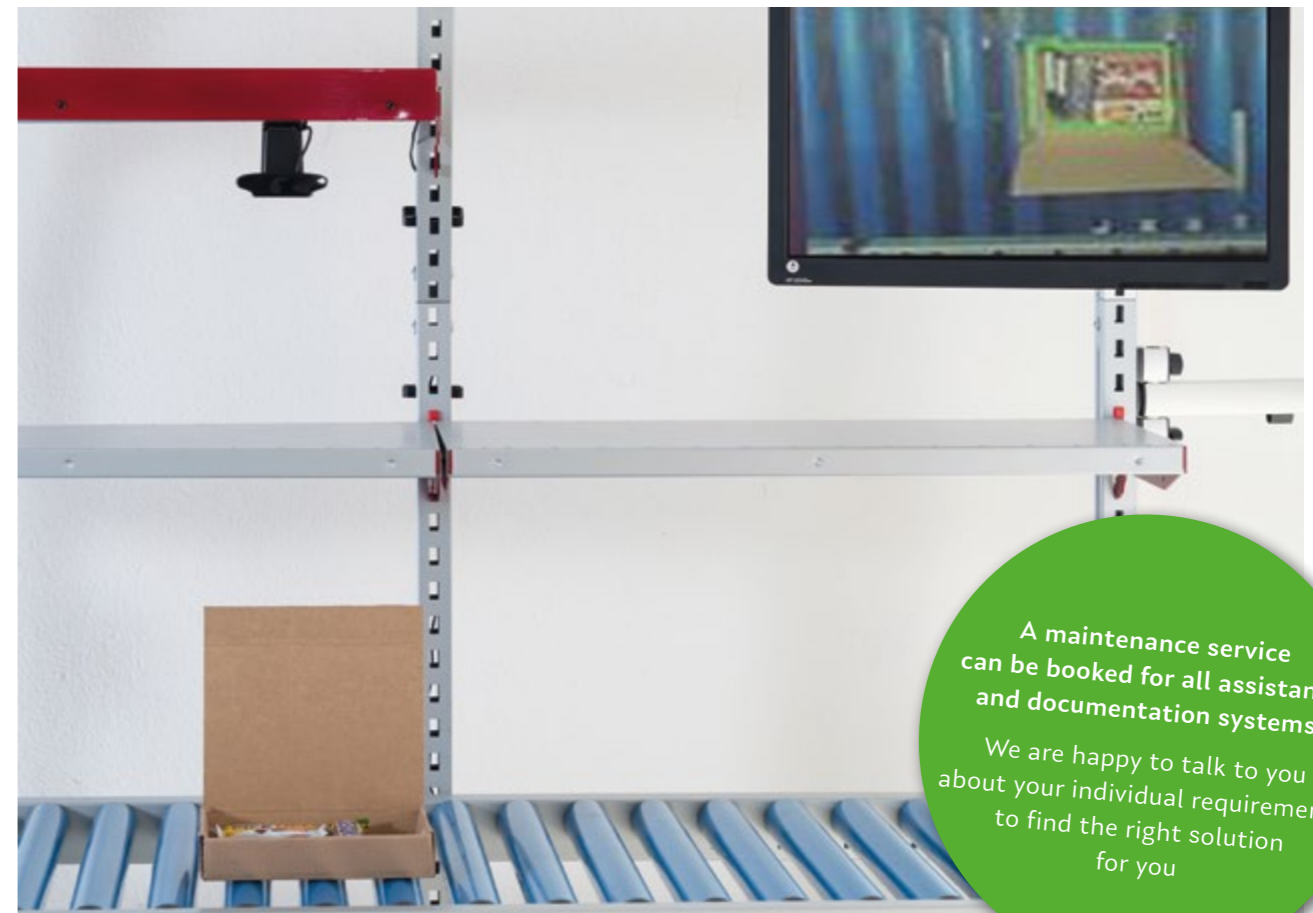

A maintenance service can be booked for all assistance and documentation systems. We are happy to talk to you about your individual requirements to find the right solution for you

InspeTable allows you to identify deviations and errors at an early stage – before the goods arrive with the customer. The image-based system compares the given situation with the pre-fed target situation, and can analyse individual articles and their layers or positions as well as the entire picture. Machine Learning not only makes it possible to distinguish

between correct and incorrect, but, depending on the intended application, also to view percentage detection data and to feed individual groups into the system. The system is characterised by the ability to adapt flexibly to different working conditions and requirements; furthermore, there is no need for broad IT-knowledge, as the set-up is so simple.

LIFTING TABLES & LIFTS



1 Mobile lift table

max. surface load 30 kg

height adjustment via gas pressure cylinder

Art. 209040 W 700 x D 800 x H 700-920 mm, weight 52 kg

2 Mobile electric lift table

electrical height adjustment, with three working height memory positions, 4 castors, 2 of which have brakes

frame in white aluminium (RAL 9006), lifting speed 38 mm/sec, max. surface load 60 kg

incl. rechargeable battery pack

Art. 209050 W 700 x D 800 x H 554-854 mm, weight 30 kg

3 Stationary electric lift table

electrical height adjustment, with three working height memory positions, frame in white aluminium (RAL 9006), lifting speed 38 mm/sec, max. surface load 60 kg

incl. power supply cable

Art. 209051 W 700 x D 800 x H 540-840 mm, weight 30 kg

4 Stationary electric lift

electrical height adjustment in the range of 360-860 mm, stroke 500 mm, frame in anthracite (RAL 7016), stainless steel platform W 450 x D 600 mm, foot switch with up/down function required, travel speed empty 64 mm/sec, with max. load 45 mm/sec, incl. power supply cable, no compressed air connection, max. surface load 50 kg

Art. 209060 W 450 x D 856 x H 970 mm, weight 40 kg



5 Pneumatic lift

platform made of stainless steel W 450 x D 600 mm, lifting speed 160 mm/sec, incl. foot switch, requires compressed air connection of 6 bar and 8 mm PU hose (not included in scope of delivery), max. surface load 60 kg

Art. 209103 W 450 x D 845 x H 1,320 mm, lifting height 250-750 mm, stroke 500 mm, weight 50 g

Art. 209104 W 450 x D 845 x H 1,720 mm, lifting height 250-950 mm, stroke 700 mm, weight 50 kg

6 Pneumatic lift for floor mounting

platform made of stainless steel W 450 x D 600 mm, lifting speed 160 mm/sec, incl. foot switch, requires compressed air connection of 6 bar and 8 mm PU hose (not included in scope of delivery), mounting material not included in scope of delivery, max. surface load 60 kg

table prepared for fixed floor mounting

Art. 209101 W 450 x D 735 x H 1,275 mm, lifting height 200-700 mm, stroke 500 mm, weight 50 kg

Art. 209102 W 450 x D 735 x H 1,675 mm, lifting height 200-900 mm, stroke 700 mm, weight 93 kg

7 Pneumatic lift table

requires compressed air connection of 6 bar and 8 mm PU hose (not included in scope of delivery), stroke 250 mm, lifting speed 160 mm/sec, max. surface load 60 kg

Art. 209100 W 600 x D 600 x H 500-710 mm, weight 25 kg



Watch video



Watch video

ERGONOMIC ACCESSORIES



1 Ergonomic workplace mat

gentle on joints and intervertebral discs, bevelled edges for reduced risk of tripping, anti-slip surface

Art. 600004 W 1,350 x D 1,000 x H 16 mm, dry version, weight 19 kg
 Art. 600005 W 1,350 x D 1,000 x H 16 mm, wet version, weight 18 kg

2 Ergonomic workplace mat puzzle

gentle on joints and intervertebral discs, bevelled edges for reduced risk of tripping, anti-slip surface

customisable for all surfaces

Art. 600007 W 1,303 x D 1,000 x H 16 mm, puzzle version D, weight 30 kg
 Art. 600009 W 1,242 x D 1,000 x H 16 mm, puzzle version E, weight 15 kg

3 ErgoPlus 3000 standing aid

incl. foot rest, foldable, max. height surface load 110 kg

infinite adjustment of the backrest and seat cushion from 600-900 mm

Art. 519192 W 670 x D 500 x H 1,100 mm, weight 12 kg



4 Saddle stool

imitation leather (black), swivel seat, seat tilt adjustment, height adjustment via gas spring
 adjustment range 660-890 mm

Art. 852086 W 478 x D 445 x H 660 mm, weight 10 kg

Motion Analysis Tools

understand processes, measure health and create solutions



Our motion analysis tools focus on improving ergonomics in work processes by analysing movement and workflow sequences in companies in detail.

These tools capture the body's joint points using a markerless 3D recording in real time. Either with a single camera from **humen dynamics** or via the latest IoT-based sensor technology from **predimo**, work movement data and processes are recorded and then analysed.

This data is crucial for optimising health, well-being and the efficiency of employees and thus also for promoting the company's efficiency.

Please get in touch, we are happy to advise you!

✉ vertrieb@rocholz.de ☎ +49 2053 819-0



IT ACCESSORIES

You can fit these accessories to any of our packing table systems. Please note that you will need an adapter or a support column for some items. We are happy to advise you!



1 PC holder

for mounting under the table, incl. fastening screws and drilling template

adjustable: interior height 307 - 531 mm, interior width 78 - 220 mm

Art. 228100 W 100-242 x D 150 x H 320-545 mm, weight 3 kg

Art. 73316700 Adapter for mounting on the feet of the electric SYSTEM FLEX tables, weight 0.2 kg

2 Mini PC holder

for mounting under the table, incl. fastening screws and drilling template

adjustable: interior height 205 - 360 mm, interior width 50 - 100 mm

Art. 228110 W 160 x D 115 x H 240-395 mm, weight 2 kg

3 Printer trolley under-table version

mobile with 4 castors, 2 with brake function, max. surface load 50 kg

with storage compartment for paper

Art. 204251

W 500 x D 600 x H 240 mm, weight 20 kg

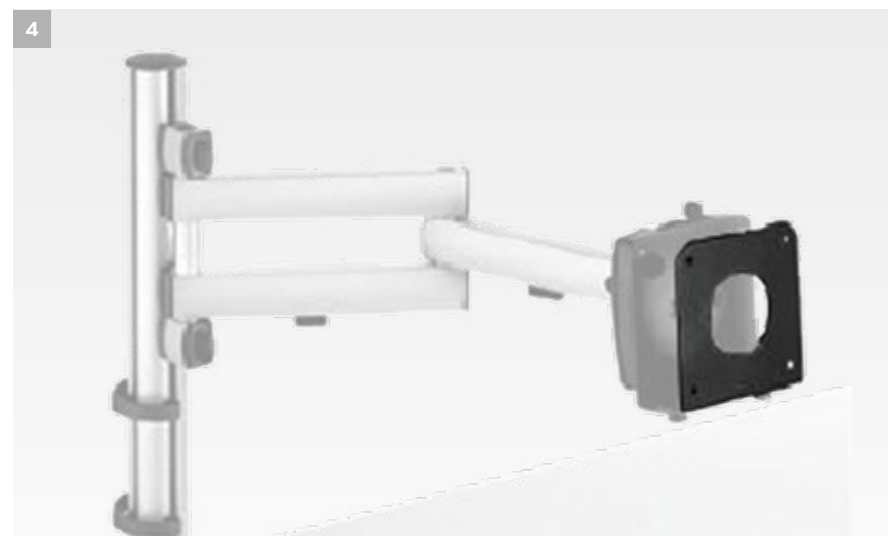

4 Thin client holder for monitor folding arm

for attaching between monitor folding arm and monitor, the holder can be continuously adjusted to the width of the thin client, max. load capacity 7.5 kg
suitable for VESA 100 x 100 mm

Art. 509211 W 35-53 mm, weight 0.9 kg

5 Upright adapter

adapter for folding arm and support carriage, for attaching monitor folding arms to the upright

Art. 509003 W 47 x D 67 x H 120 mm, weight 0.47 kg
Art. 509004 W 47 x D 67 x H 200 mm, weight 0.8 kg

6 Tablet holder

for attaching to monitor folding arms (support arm not included), VESA 75/100 quick-release attachment, clamping length 160-300 mm
for tablets from 7" to 10"

Art. 509214 weight 0.5 kg

7 Support column with screw clamp

aluminium profile with clamp attachment

for attaching a monitor folding arm and a keyboard tray

Art. 509001 W 51 x D 51 x H 445 mm, weight 1.5 kg, clamping range 14-40 mm
Art. 509002 W 51 x D 51 x H 445 mm, weight 2 kg, clamping range 5-70 mm
Art. 509006 W 51 x D 51 x H 845 mm, weight 2.7 kg, clamping range 5-65 mm

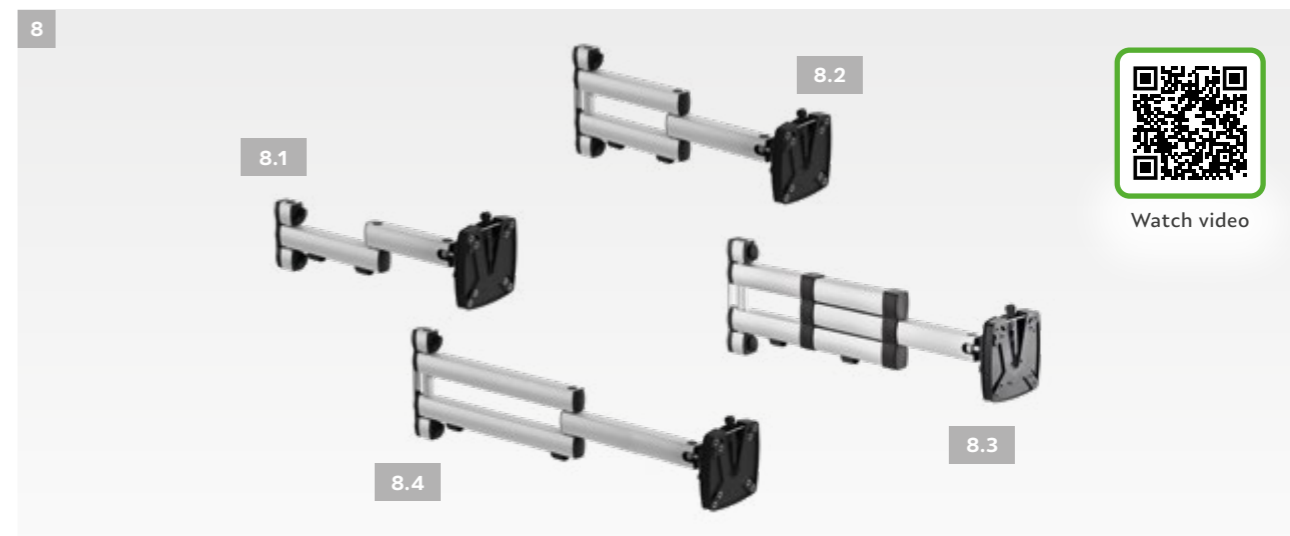

8 Monitor folding arm

for flexible mounting of a monitor in the system groove of Rocholz profiles with perforation, support column (509001, 509002, 509006), profile rail (509005) or upright adapter (509003), incl. cable holder

VESA 75/100 quick-release attachment

8.1 Art. 509203 W 100 x D 450 x H 120 mm, weight 2 kg, max. load capacity 10 kg
8.2 Art. 509204 W 100 x D 505 x H 200 mm, weight 2.1 kg, max. load capacity 15 kg
8.3 Art. 509207 W 100 x D 456-704 x H 200 mm, weight 2.5 kg, max. load capacity 8 kg
8.4 Art. 509209 W 100 x D 700 x H 200 mm, weight 2.5 kg, max. load capacity 10 kg

9 Monitor support carriage

for flexible attachment of a monitor to the support column, profile rail, in the system groove of the Rocholz profiles with perforation or on the upright adapter (509003)

max. load capacity 12 kg

Art. 509202 W 100 x D 125 H 115 mm, weight 1 kg

10 Profile rail for folding arm for IT

attachment to upright with 2 clamp sections, with 3 fastening grooves

suitable for double workstations

Art. 509005 H 745 mm, weight 2 kg





11 Double monitor holder

simple solution for monitor folding arms, VESA 75/100 quick-release attachment, suitable for monitor widths of 405-695 mm each and max. 6.4 kg (equals monitors up to approx. 30"), monitor holder has a fixed concave alignment of 7.5° on each side

Please observe the maximum total load capacity of the combined monitor folding arm!

Art. 509217 W 775 mm, weight 2.4 kg



12 Double monitor holder with gas pressure spring

2-part monitor support arm with traverse and gas pressure spring for double monitor mounting (without fastening), VESA 75/100 quick-release attachment, for 2 monitors up to max. 7 kg, for mounting to Rocholz profile with perforation (509250) or on the table (509251)

height-adjustable 180 - 480 mm

Art. 509249 weight 5.1 kg

13 Universal shelf with double folding arm

can be mounted flexibly in height using the enclosed adapter in the system groove of the Rocholz mounting profiles with perforation, max. surface load 15 kg

swivelling range 325 mm + 200 mm

Art. 73311100 W 304 x D 500 mm, shelf W 300 x D 496 mm, weight 6.5 kg



14 Folding support arm with tray

for flexible attachment in the system grooves of the Rocholz mounting profiles with perforation or on the upright adapter (509004), fixed adjustable inclination at 0°, 15° and 30°, tray area W 300 x D 400 mm, max. surface load 30 kg

for holding e.g. devices, machines and boxes

Art. 509245 W 100 x H 201 mm, arm length 350 mm, weight 3.96 kg
 Art. 509246 W 100 x H 201 mm, arm length 500 mm, weight 4.77 kg
 Art. 509247 W 100 x H 201 mm, arm length 700 mm, weight 4.6 kg

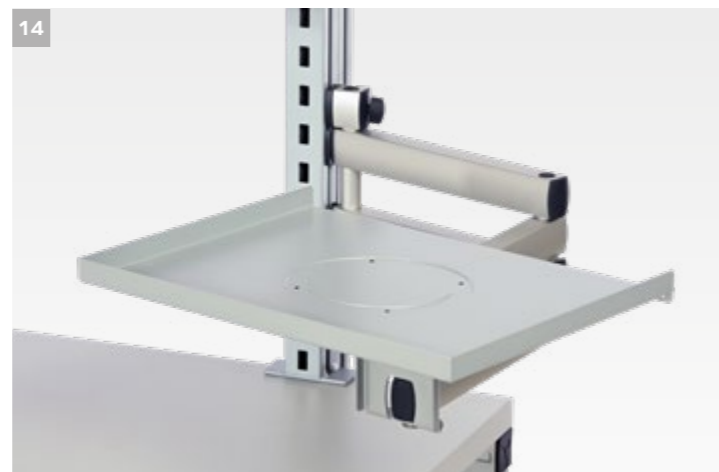

15 Keyboard and mouse platform with folding arm

for flexible mounting in the system grooves of the Rocholz mounting profiles with perforation, support column (509001, 509002, 509006), profile rail (509005) or upright adapter (509003), platform 640 x 172 mm, tiltable up to 25°, rotatable and swivelling, reach 728 mm

max. surface load 10 kg

Art. 509201 W 640 x D 728 x H 120 mm, weight 3.5 kg

16 Retractable keyboard tray

extendable mouse tray can be pulled out to the left or right, under-table mounting, interior dimensions keyboard tray W 527 x D 250 mm, RAL 9006 white aluminium

minimum tabletop thickness 25 mm

Art. 509318 W 577 x D 290 x H 119 mm, weight 4.1 kg

17 Notebook tray with folding arm

for flexible mounting in the system grooves of Rocholz mounting profiles with perforation, support column (509001, 509002, 509006), profile rail (509005) or upright adapter (509003), cable opening in the platform, reach 589 mm

max. surface load 10 kg

Art. 509213 W 404 x D 589 x H 120 mm, tray W 404 x D 288 mm, weight 1.5 kg



ACCESSORIES FOR PERFORATED BACK PANELS

Bring order and efficiency to your work area. Being able to simply hang and change accessories at any time allows you to make the best use of your workspace and adapt it to fit your individual processes. Our accessories make your working environment more flexible than ever.



1 Open front storage boxes size 7

without holder, 1 sales unit = 5 pcs.

Art. 704707 W 105 x D 160 x H 75 mm, weight 0.6 kg

2 Adapter for open front storage boxes

for attaching to a perforated back panel, space for 5 storage boxes size 7

Art. 207010 W 550 x H 58 mm, weight 5.6 kg

All hooks are also available individually, on request. Feel free to contact us!

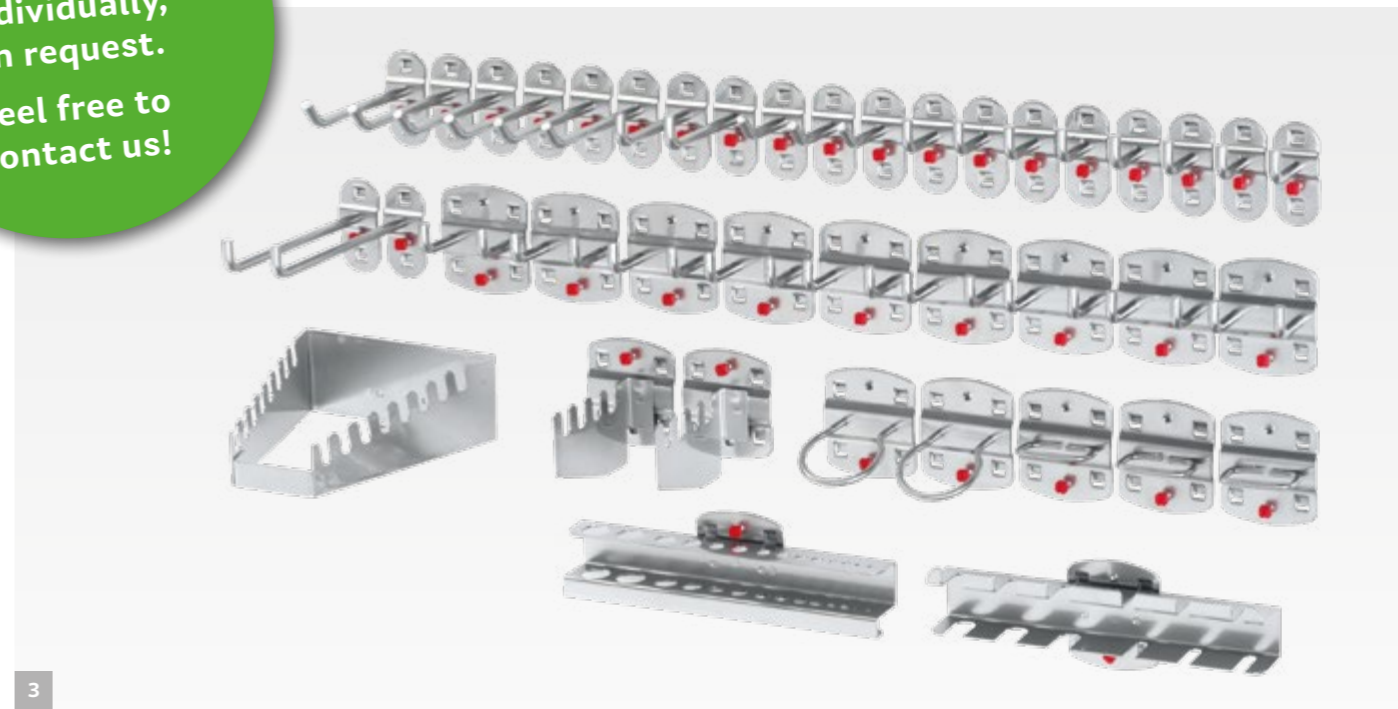

3

3 Tool holder set

impact and scratch resistant coating

- | | |
|---------------|---|
| Art. 86000039 | 4 x tool holder vertical hook end L 35 mm,
3 x tool holder double vertical hook end L 35 mm,
1 x plier holder W 35 x D 20 mm,
1 x machine tool holder Ø 40 mm,
3 x tool holder oblique hook end L 100 mm,
weight 1.2 kg |
| Art. 86000040 | 3 x tool holder oblique hook end L 50 mm,
6 x tool holder oblique hook end L 100 mm,
8 x tool holder vertical Hook end L 35 mm,
2 x tool holder vertical hook end L 75 mm,
2 x tool holder vertical hook end L 125 mm,
9 x tool holder double vertical hook end L 35 mm,
3 x plier holder W 35 x D 20 mm,
2 x machine tool holder Ø 40 mm,
1 x spanner holder horizontal,
1 x screwdriver holder 6 pcs,
1 x drill bit holder 14 pcs,
1 x saw holder for 4 saws,
weight 2.3 kg |

ACCESSORIES FOR PERFORATED BACK PANELS

4 Storage box large

impact and scratch resistant coating, stamped base plate 1.5 mm thick

Art. 86000032 W 320 x D 135 x H 55 mm, weight 2 kg

5 Spanner holder

impact and scratch resistant coating, for 8 spanners

Art. 86000033 W 130/60 x D 150 x H 50 mm, weight 0.1 kg

6 Screwdriver holder

impact and scratch resistant coating

Art. 86000034 W 200 x D 30 x H 40 mm, for 6 items, weight 0.1 kg
 Art. 86000035 W 390 x D 30 x H 40 mm, for 12 items, weight 0.1 kg

7 Drill bit/Allen key holder

impact and scratch resistant coating, for various diameters

Art. 86000036 W 200 x D 30 x H 35 mm, for 14 items, weight 0.1 kg
 Art. 86000037 W 390 x D 30 x H 35 mm, for 28 items, weight 0.1 kg

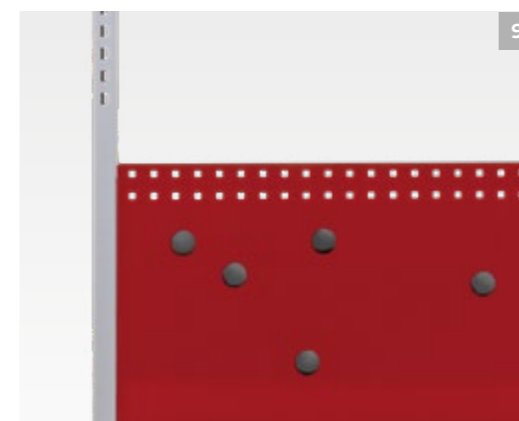
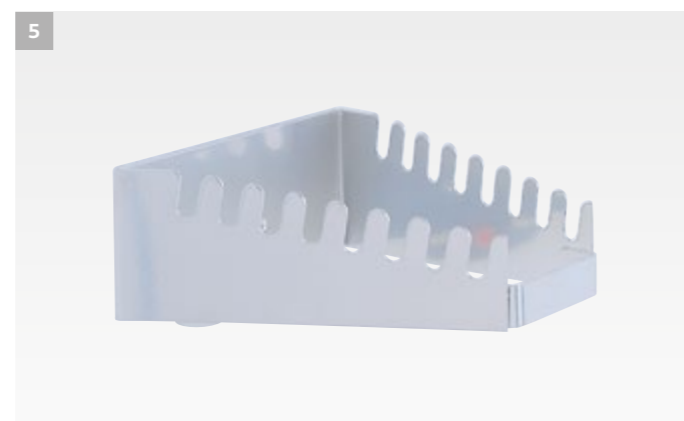
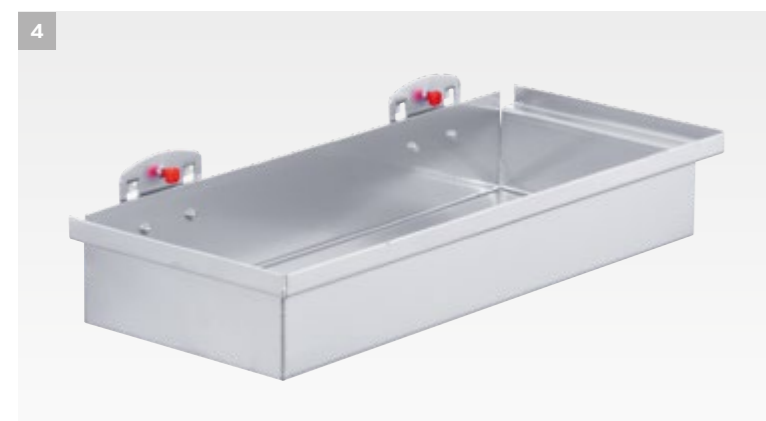

8 Document tray

impact and scratch resistant coating, stamped base plate 1.5 mm thick

Art. 86000038 W 225 x D 310 x H 85 mm, weight 1.12 kg

9 Magnet set

1 sales unit = 5 pcs.

Art. 509321 Ø 18 mm, weight 0.03 kg

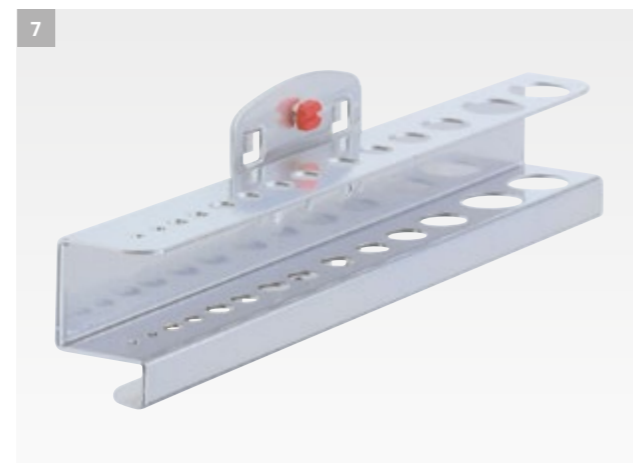
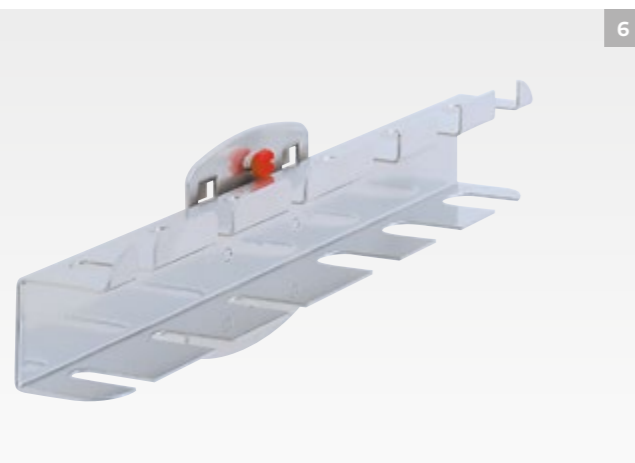

All tool holder systems from 3-8 are "GS" safety tested and aluminium-coloured.

OTHER ACCESSORIES



1 Cut-resistant overlay

is bonded to table top with the supplied adhesive pads

protects parts of the table top from damage under mechanical strain

Art. 203095 W 1,000 x D 800 x H 1 mm, stainless steel, weight 13 kg

Art. 203096 W 1,000 x D 800 x 1 mm, galvanised sheet steel, weight 12 kg



2 Cut-resistant overlay transparent

for traceless cuts (the mat „closes“ again and the cut becomes invisible), less wear on blades due to soft surface

slight anti-slip effect

Art. 509400 W 900 x D 600 x H 3 mm, weight 2 kg

3 Display panel holder with magnetic attachment

quick and easy attachment to metal surfaces, black display panel holder for A4

metal wall holder with magnetic back

Art. 591401

with 5 display panels, weight 0.4 kg

Art. 591801

with 10 display panels, weight 1.1 kg



4 Display panel A4

5 display panels, made of polypropylene with all-round black profile frame for A4

Art. 560601

weight 0.6 kg

5 Display panel holder as table stand

with 10 display panels, 2 in black, red, yellow, green and dark blue, respectively, in A4 format, incl. tabs with blank insert labels

complete set made of powder-coated sheet steel for table top use

Art. 557000

weight 2 kg



OTHER ACCESSORIES

6 Storage container

durable and reusable, for hygienic applications, rigid, chemically inactive, non-toxic, colour grey, material 3.5 mm polypropylene 800 g/m²
mould and moisture proof

Art. 2056 W 600 x D 500 x H 600 mm, weight 2.5 kg

7 Trolley for 90 litre rubbish bins

carriage white varnished metal, total height when using with rubbish bin 740 mm

four castors

Art. 99090240 W 385 x D 395 x H 180 mm, weight 3.3 kg

8 Rubbish bin

with handles for easy transportation

holding capacity 90 litres

Art. 99090241 W 520 x D 490 x H 610 mm, weight 3 kg

9 Mobile carton storage rack

with handle, max. surface load top rack 50 kg, max. surface load 300 kg

two levels

9.1 Art. 2042-2 W 1,015 x D 600 x H 1,260 mm, short for approx. 200 folding cartons, weight 43 kg

9.1 Art. 2043-2 W 1,600 x D 600 x H 1,260 mm, long for approx. 320 folding cartons, weight 64 kg

three levels

9.2 Art. 2042-3 W 1,015 x D 600 x H 1,860 mm, short for approx. 300 folding cartons, weight 64 kg

9.2 Art. 2043-3 W 1,600 x D 600 x H 1,860 mm, long for approx. 480 folding cartons, weight 95 kg



10 Mobile hanging frame for filling material

optionally with extension strut and bracket

360° swivel mounted

Art. 2046 W 1,050 x D 700 x H 2,100-3,500 mm, weight 45 kg

Art. 802045 extension strut and bracket, weight 2 kg

11 Carton securement for roller track tables

end stop made of galvanised sheet steel, in white aluminium (RAL 9006)

for roller track width 600 mm

Art. 203542 W 613 x D 318 x H 141 mm, weight 2.94 kg

12 Carton securement under table top

for screwing under the table top, in white aluminium (RAL 9006)

not suitable for tables with electrical height adjustment

Art. 203543 W 350 x D 120 x H 70 mm, weight 0.8 kg

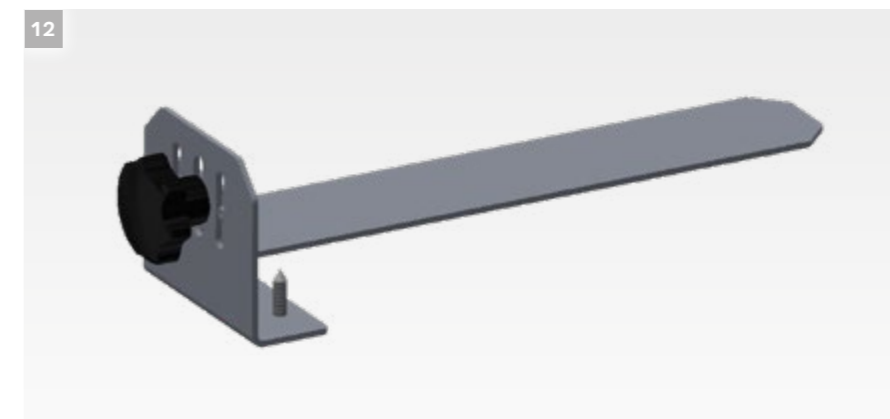
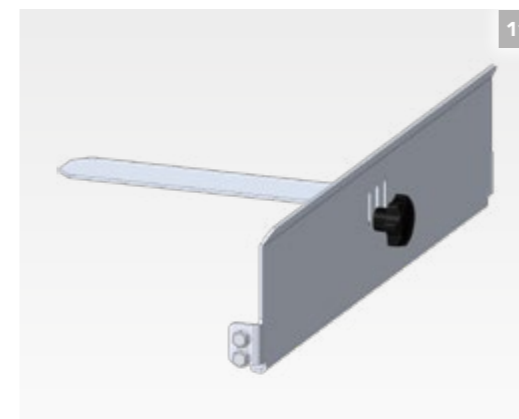

13 Table trolley

with one shelf infinitely height-adjustable from 245-745 mm, in white aluminium (RAL 9006), top shelf W 500 x D 405 mm incl. two stop edges, bottom shelf W 400 x D 320 mm incl. one stop edge (max. surface load 15 kg), with adjustable inclination 0°/15°/30°, max. surface load 60 kg

4 castors, 2 with brakes

Art. 73313700 W 405 x D 500 x H 800 mm, weight 12.4 kg

Image without stop edges

02

Cutting systems



CUTTING SYSTEMS

Experience exquisite cutting results with the cutting systems from Rocholz GmbH. For the use of roll material such as paper, corrugated cardboard or film, we offer you tried-and-tested cutting systems with dispensers. Your cutter stand can be placed freely in the room, or integrated directly into the packing workplace.



The sturdy Rocholz cutting systems enable safe, fast and convenient cutting of roll material. Two cutter cartridges for different materials such as paper, cardboard and film (also ideal for cutting film hoods) are included as standard and can be exchanged easily.

A clamping mechanism ensures easy insertion of the material and safe re-gripping after each cut. You can place the cutter stand anywhere in the room or integrate it directly into your packing workplace for faster processes.

We supply
two cutter cartridges
as standard!



Watch video



EASY CHANGE

The cutter cartridges can be exchanged quickly, easily and without tools:
The round cutter for paper, corrugated cardboard etc. or the blade for all soft films.
A clamping mechanism ensures easy insertion of the material
and safe re-gripping after each cut.

We supply two cutter cartridges as standard!

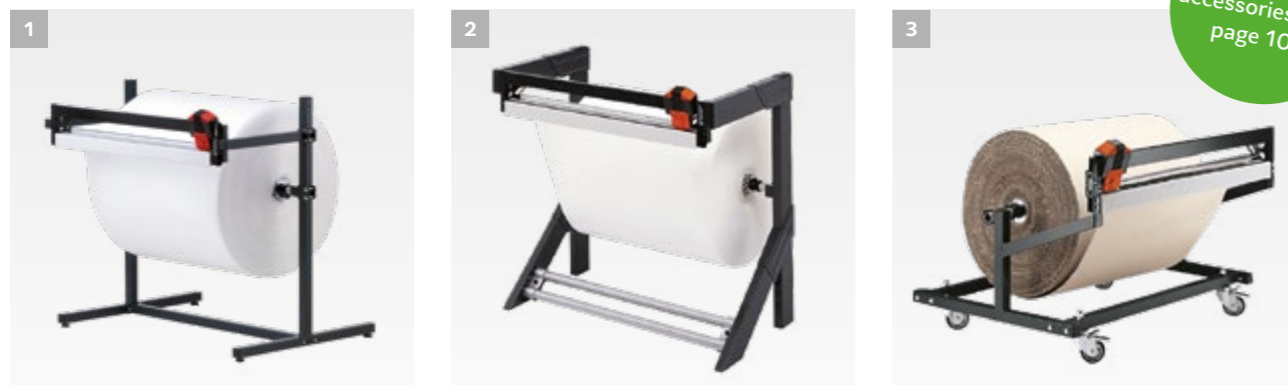

1 SYSTEM horizontal cutter stand

material dispensing height infinitely adjustable, max. roll weight 100 kg

max. roll-Ø 800 mm

Art. 26207N	W 1,120 x D 850 x H 1,165 mm, cutting width 750 mm, weight 26.2 kg
Art. 26210N	W 1,370 x D 850 x H 1,165 mm, cutting width 1,000 mm, weight 29.1 kg
Art. 26212N	W 1,620 x D 850 x H 1,165 mm, cutting width 1,250 mm, weight 30.1 kg
Art. 26216N	W 1,970 x D 850 x H 1,165 mm, cutting width 1,600 mm, weight 34.1 kg
Art. 26218N	W 2,170 x D 850 x H 1,165 mm, cutting width 1,800 mm, weight 37.5 kg
Art. 26220N	W 2,370 x D 850 x H 1,165 mm, cutting width 2,000 mm, weight 39.9 kg

2 MODUL horizontal cutter stand

dispensing height 890 mm, spindle tube Ø 32 mm, core diameter 60-85 mm, max. roll weight 200 kg

max. roll-Ø 1,000 mm

Art. 55307	W 1,090 x D 970 x H 1,060 mm, cutting width 750 mm, weight 39 kg
Art. 55310	W 1,340 x D 970 x H 1,060 mm, cutting width 1,000 mm, weight 41.7 kg
Art. 55312	W 1,590 x D 970 x H 1,060 mm, cutting width 1,250 mm, weight 44 kg
Art. 55316	W 1,940 x D 970 x H 1,060 mm, cutting width 1,600 mm, weight 47 kg

3 SYSTEM mobile under-table cutter stand

dispensing height 580 mm, 4 castors, 2 of which have brakes, max. height 580 mm. roll weight 200 kg

max. roll-Ø 750 mm

Art. 25507	W 1,000 x D 880 x H 740 mm, cutting width 750 mm, weight 23 kg
Art. 25510	W 1,250 x D 880 x H 740 mm, cutting width 1,000 mm, weight 26 kg
Art. 25512	W 1,500 x D 880 x H 740 mm, cutting width 1,250 mm, weight 28 kg
Art. 25516	W 1,850 x D 880 x H 740 mm, cutting width 1,600 mm, weight 32 kg



4 MODUL mobile under-table cutter stand

dispensing height 544 mm, 4 castors, 2 with brakes, spindle tube Ø 32 mm, core diameter 60-85 mm, max roll weight 200 kg

max. roll-Ø 750 mm

Art. 55507	W 1,090 x D 740 x H 710 mm, cutting width 750 mm, weight 38 kg
Art. 55510	W 1,340 x D 740 x H 710 mm, cutting width 1,000 mm, weight 40 kg
Art. 55512	W 1,590 x D 740 x H 710 mm, cutting width 1,250 mm, weight 42 kg
Art. 55516	W 1,940 x D 740 x H 710 mm, cutting width 1,600 mm, weight 45 kg

5 SYSTEM double cutter stand with one cutting device

infinitely adjustable dispensing height, spindle tube Ø 32 mm, core diameter 60-85 mm, max. total roll weight 130 kg

max. roll-Ø 800 mm

Art. 26507	W 1,120 x D 850 x H 1,665 mm, cutting width 750 mm, weight 38 kg
Art. 26510	W 1,370 x D 850 x H 1,665 mm, cutting width 1,000 mm, weight 40.5 kg
Art. 26512	W 1,620 x D 850 x H 1,665 mm, cutting width 1,250 mm, weight 42 kg
Art. 26516	W 1,970 x D 850 x H 1,665 mm, cutting width 1,600 mm, weight 47 kg
Art. 26518	W 2,170 x D 850 x H 1,665 mm, cutting width 1,800 mm, weight 51 kg
Art. 26520	W 2,370 x D 850 x H 1,665 mm, cutting width 2,000 mm, weight 57 kg

6 SYSTEM double cutter stand with two cutting devices

infinitely adjustable dispensing height, spindle tube Ø 32 mm, core diameter 60-85 mm, max. total roll weight 130 kg

max. roll-Ø 800 mm

Art. 26407	W 1,120 x D 850 x H 1,665 mm, cutting width 750 mm, weight 45 kg
Art. 26410	W 1,370 x D 850 x H 1,665 mm, cutting width 1,000 mm, weight 50 kg
Art. 26412	W 1,620 x D 850 x H 1,665 mm, cutting width 1,250 mm, weight 52 kg
Art. 26416	W 1,970 x D 850 x H 1,665 mm, cutting width 1,600 mm, weight 60 kg
Art. 26418	W 2,170 x D 850 x H 1,665 mm, cutting width 1,800 mm, weight 65 kg
Art. 26420	W 2,370 x D 850 x H 1,665 mm, cutting width 2,000 mm, weight 69 kg

7 MODUL double cutter stand with two cutting devices

dispensing height 890/1,215 mm, spindle tube Ø 32 mm, core diameter 60-85 mm, max. roll weight per roll 150 kg

max. roll-Ø 750 mm

Art. 55407	W 1,090 x D 970 x H 1,740 mm, cutting width 750 mm, weight 60 kg
Art. 55410	W 1,340 x D 970 x H 1,740 mm, cutting width 1,000 mm, weight 63 kg
Art. 55412	W 1,590 x D 970 x H 1,740 mm, cutting width 1,250 mm, weight 68 kg
Art. 55416	W 1,940 x D 970 x H 1,740 mm, cutting width 1,600 mm, weight 73.5 kg

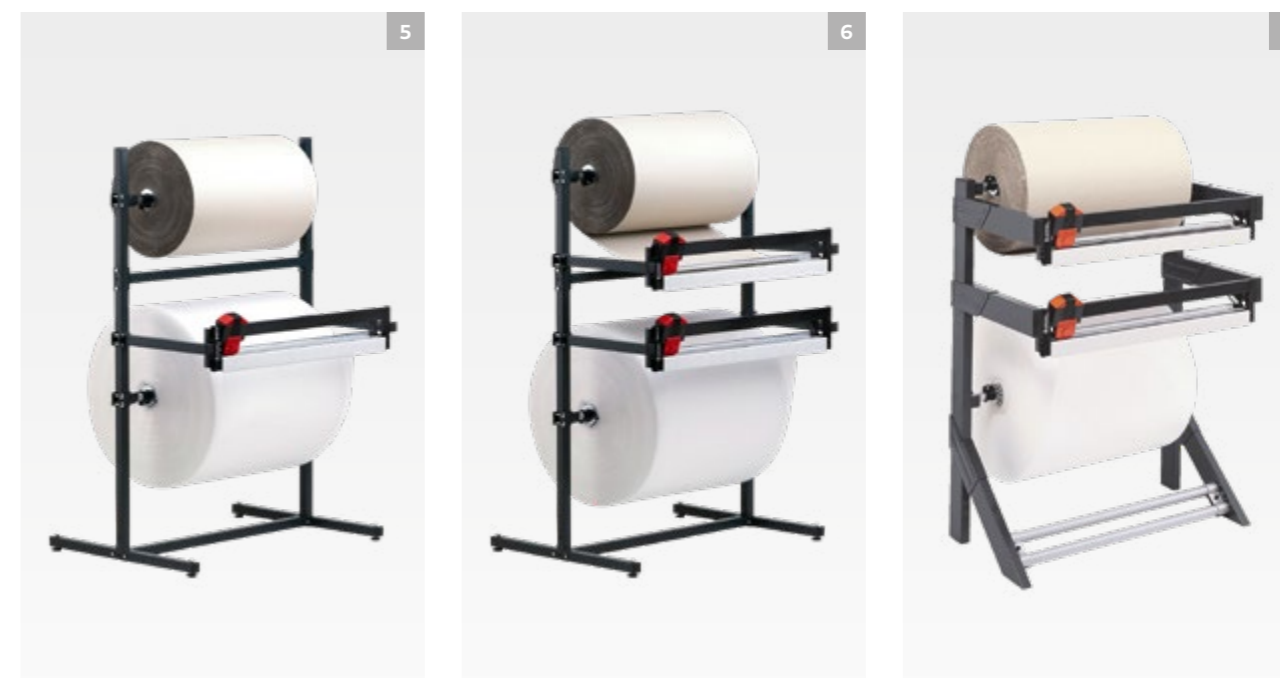

1 SYSTEM wall-mounted cutting system

spindle tube Ø 32 mm, fixing material is not included in scope of delivery

max. roll weight 80 kg, max. roll-Ø 250 mm

Art. 25907	W 1,000 x D 400 x H 460 mm, cutting width 750 mm, weight 15 kg
Art. 25910	W 1,250 x D 400 x H 460 mm, cutting width 1,000 mm, weight 17 kg
Art. 25912	W 1,500 x D 400 x H 460 mm, cutting width 1,250 mm, weight 20 kg
Art. 25916	W 1,850 x D 400 x H 460 mm, cutting width 1,600 mm, weight 23 kg

max. roll weight 200 kg, max. roll-Ø 500 mm

Art. 26007	W 1,000 x D 670 x H 570 mm, cutting width 750 mm, weight 21 kg
Art. 26010	W 1,250 x D 670 x H 570 mm, cutting width 1,000 mm, weight 24 kg
Art. 26012	W 1,500 x D 670 x H 570 mm, cutting width 1,250 mm, weight 26.6 kg
Art. 26016	W 1,850 x D 670 x H 570 mm, cutting width 1,600 mm, weight 30 kg



2 SYSTEM table-top cutting system

spindle tube Ø 32 mm, with one cutting device

max. roll weight 80 kg, max. roll-Ø 250 mm

Art. 25607	W 1,000 x D 341 x H 340 mm, cutting width 750 mm, weight 12 kg
Art. 25610	W 1,250 x D 341 x H 340 mm, cutting width 1,000 mm, weight 14.7 kg
Art. 25612	W 1,500 x D 341 x H 340 mm, cutting width 1,250 mm, weight 15.9 kg
Art. 25616	W 1,850 x D 341 x H 340 mm, cutting width 1,600 mm, weight 19.8 kg

max. roll weight 200 kg, max. roll-Ø 500 mm

Art. 25707	W 1,000 x D 600 x H 470 mm, cutting width 750 mm, weight 19 kg
Art. 25710	W 1,250 x D 600 x H 470 mm, cutting width 1,000 mm, weight 22 kg
Art. 25712	W 1,500 x D 600 x H 470 mm, cutting width 1,250 mm, weight 24 kg
Art. 25716	W 1,850 x D 600 x H 470 mm, cutting width 1,600 mm, weight 28 kg



3 SYSTEM mobile vertical cutter stand

max roll weight 200 kg

max. roll-Ø 800 mm

Art. 35110	W 800 x D 880 x H 1,295 mm, cutting width 1,000 mm, weight 25.5 kg
Art. 35112	W 800 x D 880 x H 1,545 mm, cutting width 1,250 mm, weight 27 kg
Art. 35116	W 800 x D 880 x H 1,895 mm, cutting width 1,600 mm, weight 30 kg
Art. 35118	W 800 x D 880 x H 2,100 mm, cutting width 1,800 mm, weight 38 kg
Art. 35120	W 800 x D 880 x H 2,300 mm, cutting width 2,000 mm, weight 40 kg



4 SYSTEM mobile vertical cutter stand

max roll weight 200 kg

max. roll Ø 450 mm

Art. 35010	W 480 x D 580 x H 1,300 mm, cutting width 1,000 mm, weight 20.8 kg
Art. 35012	W 480 x D 580 x H 1,550 mm, cutting width 1,250 mm, weight 22.3 kg
Art. 35016	W 480 x D 580 x H 1,900 mm, cutting width 1,600 mm, weight 26 kg



Watch video

5 MODUL roll dispenser mobile

4 castors, 2 with brakes, max. roll weight 200 kg

max. roll-Ø 750 mm

Art. 53107	W 1,090 x D 770 x H 680 mm, roll width 750 mm, weight 28 kg
Art. 53110	W 1,340 x D 770 x H 680 mm, roll width 1,000 mm, weight 29 kg
Art. 53112	W 1,590 x D 770 x H 680 mm, roll width 1,250 mm, weight 31 kg



ESD accessories from page 100

6 SYSTEM roll dispenser mobile

4 castors, 2 with brakes, max. load capacity roll width 750 mm, max roll weight 200 kg

max. roll-Ø 500 mm

Art. 23107	W 1,000 x D 600 x H 400 mm, weight 13 kg
Art. 23110	W 1,250 x D 600 x H 400 mm, weight 15 kg
Art. 23112	W 1,500 x D 600 x H 400 mm, weight 17 kg

max. roll-Ø 750 mm

Art. 23207	W 1,000 x D 840 x H 500 mm, weight 15.3 kg
Art. 23210	W 1,250 x D 840 x H 500 mm, weight 18 kg
Art. 23212	W 1,500 x D 840 x H 500 mm, weight 18 kg

PNEUMATIC CUTTER

- ✓ Safe usage and ergonomic handling, especially with large cutting widths
- ✓ Consistent cutting quality
- ✓ Low fatigue, even for greater volumes, practicable for large widths (up to 1600 mm cutting width)
- ✓ Compressed air connection max. 6 bar required



The pneumatically powered cutter is used for cutting packaging materials such as paper, tissue paper, kraft paper, corrugated cardboard, anti-rust paper, soft flat film, foam sheets, bubble wrap, tubular film, etc. Foam sheets can have a max. thickness of 6 mm,

bubble wrap of 10 mm. Special papers and kraft papers over 180 gsm must be tested for their cutting suitability. The same applies to flat and tubular films over 200 my. We are happy to test your material – please get in touch!

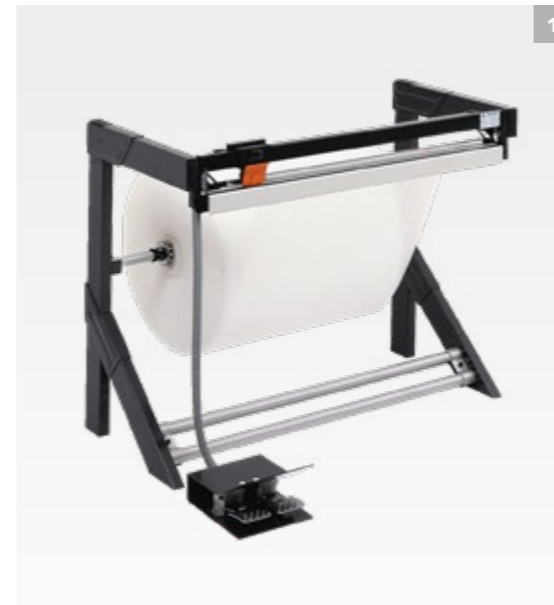

1 MODUL horizontal pneumatic cutter

compressed air connection max. 6 bar, max. roll weight 200 kg

max. roll-Ø 750 mm

Art. 57310	W 1,730 x D 970 x H 1,060 mm cutting width 1,000 mm, weight 61 kg
Art. 57312	W 1,980 x D 970 x H 1,060 mm cutting width 1,250 mm, weight 63 kg
Art. 57316	W 2,330 x D 970 x H 1,060 mm cutting width 1,600 mm, weight 66 kg

2 Pneumatic add-on cutter

compressed air connection max. 6 bar, for rear edge of table, clamping range 20-70 mm suitable for SYSTEM 2000 and MODUL 5000

Art. 57112	W 1,980 x D 235 x H 200 mm cutting width 1,250 mm, weight 38 kg
------------	---



The cutting speed can be adjusted on both models. Factory setting approx. 1.5 m/sec.



1 SYSTEM roll stand with tear-off device

for pre-perforated material, max. roll Ø 800 mm, max. roll weight 100 kg

Art. 26207AV	W 1,120 x D 920 x H 1,165 mm, roll width 750 mm, weight 20 kg
Art. 26210AV	W 1,370 x D 920 x H 1,165 mm, roll width 1,000 mm, weight 23 kg
Art. 26212AV	W 1,620 x D 920 x H 1,165 mm, roll width 1,250 mm, weight 24 kg
Art. 26216AV	W 1,970 x D 920 x H 1,165 mm, roll width 1,600 mm, weight 25 kg
Art. 26218AV	W 2,170 x D 920 x H 1,165 mm, roll width 1,800 mm, weight 26 kg
Art. 26220AV	W 2,370 x D 920 x H 1,165 mm, roll width 2,000 mm, weight 27 kg

2 MODUL roll runners

4 castors, 2 with brakes, max. load capacity per runner 75 kg

only for art. 553... (horizontal cutter stands)

Art. 5554	W 52 x D 650 x H 100 mm, weight 3 kg
-----------	--------------------------------------

3 Swivel castors

4 castors, 2 of which have brakes, red/black plastic, castor diameter 75 mm, max. load capacity per castor 70 kg

only for art. 262..., 264... and 265... (horizontal cutter stands)

Art. 23601	H 106 mm, weight 1 kg
------------	-----------------------



4 Metre counter

suitable for horizontal cutter stands 262..., 264..., 265..., 553... and 554...

Art. 256075	W 1,000 x D 155 x H 155 mm, for roll width 750 mm, weight 2.3 kg
Art. 256100	W 1,250 x D 155 x H 155 mm, for roll width 1,000 mm, weight 2.5 kg
Art. 256125	W 1,500 x D 155 x H 155 mm, for roll width 1,250 mm, weight 2.7 kg
Art. 256160	W 1,850 x D 155 x H 155 mm, for roll width 1,600 mm, weight 3.1 kg
Art. 256180	W 2,050 x D 155 x H 155 mm, for roll width 1,800 mm, weight 3.5 kg
Art. 256200	W 2,250 x D 155 x H 155 mm, for roll width 2,000 mm, weight 3.8 kg



I. Scope of application

The following terms and conditions of sale shall apply to all contracts, deliveries and other services unless they are amended or excluded with our express consent. Our contractual partner's terms and conditions shall not become binding even if we do not expressly object to them.

II. Offer and conclusion

1. Offers made by us are always subject to confirmation. Conclusions of contracts and other agreements with us shall only become binding upon our written confirmation or upon our delivery.
2. Our employees are not authorised to make verbal subsidiary agreements to contractual agreements or to give assurances which go beyond the written contracts. The effectiveness of such agreements is in any case dependent on our written confirmation.

III. Technical specifications, tools and drawings

1. Illustrations, weights and dimensions are non-binding. We reserve the right to make design changes. Details and information on the suitability and application of our products are non-binding and do not release the purchaser from his own tests and trials, which must be carried out in every case.
2. Drawings and other documents relating to the products supplied or offered by us remain our property. They may only be used for the contractually intended purpose without special consent. The passing on and disclosure to third parties as well as the use by the contractual partner beyond the contractual purpose requires our written consent. In the event of an infringement, a contractual penalty of 10,000- EUR shall be forfeited. The drawings and other documents are to be returned at our request.
3. Tools, auxiliary tools and apparatus for the manufacture of the goods shall remain our property even if costs have been charged to the customer for them. After the expiry of the first two years after manufacture or acquisition, we shall only retain these items free of charge for further orders if at least 80 % of the annual purchase quantity on which the item bid is based is achieved each year.

IV. Prices and payments

1. Unless otherwise agreed, the following terms of delivery shall apply:
Domestic
 - The minimum order value is 250.00 EUR net. If the value of the goods is less than this, an additional flat-rate handling fee of 25.00 EUR shall be charged.
 - Deliveries within Germany are free of charge.
 - The prices do not include the statutory value-added tax.
 - Spare parts are invoiced at net prices.**Export**
 - The minimum order value is 1500.00 EUR net. If the value of the goods is less than this, an additional flat-rate handling fee of 50.00 EUR plus freight will be charged.
 - Deliveries will be made EXW from 1500.00 EUR net.
 - Spare parts are invoiced at net prices.

The agreed prices correspond to the cost situation at the time of conclusion of the contract. Should the costs for materials, wages or other price-forming factors increase or decrease until delivery, we reserve the right to invoice the order at our prices valid on the day of delivery. For goods for which we have issued price lists, the price list valid at the time of delivery shall apply.

2. We insure all goods against loss and damage and charge a premium of 1 per mille of the net order value. We shall only waive the conclusion of insurance if expressly instructed to do so.
3. We do not accept bills of exchange as a matter of principle, so that we are not obliged to return bills of exchange sent to us.

4. In the absence of a special agreement, the following payment terms shall apply
 - a) In the case of machines and electrical cutting equipment, 1/3 down payment when the order is placed, 1/3 payment on delivery and 1/3 payment of the balance net cash 30 days after the invoice date.
 - b) For pressed, stamped and drawn parts as well as apparatus and packaging equipment, net cash in advance.
 - c) In the case of tools and devices, immediately after receipt of the outturn samples, net without deduction.
5. In the event of payment terms being exceeded and in the event of default, we shall be entitled to charge interest at the rate of our current account interest rate, but at least 5% above the respective ECB discount rate.
6. Offsetting with any counterclaims disputed by us is not permitted unless these have been legally established. The assertion of a right of retention against our claims shall be excluded, unless complaints about defects in the delivered goods are raised from the same contractual relationship.

The right of retention may only be claimed to the amount of the costs of rectifying the defect.

V. Creditworthiness

If, after acceptance of the order, justified doubts arise as to the solvency or creditworthiness of the customer, we shall be entitled to demand either cash payment or advance payment or to withdraw from the contract and demand reimbursement of our expenses from the customer. A delivery of goods shall only be made upon settlement of the overdue open items.

VI. Dispatch and transfer of risk

Subject to deviating agreements, the route and means of dispatch shall be left to our choice. Dispatch shall be at the expense and risk of the customer. If dispatch is delayed at the request or fault of the customer, the goods shall be stored at the expense and risk of the customer. In this case, notification of readiness for dispatch is equivalent to dispatch.

VII. Packaging

- Packaging in cartons is included in the price.
- Packaging in boxes, crates, containers or on one-way pallets shall be charged separately.
- Packaging will not be taken back.
- Box pallets are returnable containers and must be returned in the same number and quality.

VIII. Delivery periods, delay and impossibility of delivery

1. Delivery periods and delivery dates shall only be deemed to be fixed if we expressly confirm the delivery period as a fixed date in writing. Otherwise, delivery dates are always only non-binding time specifications which we endeavour to meet and are always understood as the date on which the goods leave our works.
2. The delivery periods shall be reasonably extended - also within a delay - in the event of force majeure and in the event of unforeseen obstacles occurring after conclusion of the contract, insofar as these obstacles have an influence on the delivery of the item sold. This also applies if these circumstances occur at our suppliers or their suppliers. In particular, strikes or lockouts shall also be deemed to be an impediment.
3. The delivery periods shall be extended by the period in which the customer is in default with his contractual obligations - within an ongoing business relationship also from other contracts.

4. Orders on call are only accepted with acceptance periods. If acceptance does not take place within the agreed period, we shall be free to deliver completed deliveries without further notice or to store them at the expense of the customer or to withdraw from our delivery obligation in whole or in part with notice or to demand compensation from the customer for non-performance.
5. In the event of delayed delivery, our customer may withdraw from the contract or assert other claims if a reasonable period of grace has been set beforehand with the indication of which rights are to be asserted after expiry of the deadline.
6. If we are responsible for delay or impossibility of delivery, any claim for damages to which the customer is entitled shall be limited to the damage foreseeable at the time of conclusion of the contract, but not more than 10 % of the value of that part of the total delivery which cannot be used on time or in accordance with the contract as a result of the delay or non-delivery. This limitation shall not apply if the contract is not related to a commercial activity of our customer and if we are liable in cases of intent or gross negligence. The right of the customer to withdraw from the contract after the fruitless expiry of a grace period granted to us with reference to the exercise of the right of withdrawal remains unaffected.

IX. Retention of title

Until the fulfilment of all claims to which we are entitled against the customer now or in the future, we shall be granted the following securities, which we shall release at our discretion on request, insofar as their value exceeds our claims by more than 20 % on a sustained basis. Delivered goods remain our property. Processing or transformation shall always be carried out for us as manufacturer, but without any obligation on our part. If the goods delivered by us are processed with other items not belonging to us, we shall acquire co-ownership of the new item in the ratio of the invoice value of the goods delivered by us to the invoice value of the other goods used at the time of processing.

If our goods are combined or inseparably mixed with other movable items to form a single item, and if the other item is to be regarded as the main item, it shall be deemed agreed that the customer transfers co-ownership to us on a pro rata basis insofar as the main item belongs to him. Items to which we are entitled to ownership or co-ownership are hereinafter referred to as reserved goods. Subject to our revocation, the buyer is entitled to sell the reserved goods in the ordinary course of business and to combine or mix them with the goods of others. The buyer hereby assigns to us any claims arising from the sale, combination or mixing or any other legal reason with regard to the goods subject to retention of title; if such claims are included in current invoices, this assignment shall also include all balance claims. In the event of access by third parties to the reserved goods, the buyer shall point out our ownership and notify us immediately. In the event of any breach of contract by the buyer - in particular default of payment - we shall be entitled to take back the goods subject to retention of title at the buyer's expense or, if applicable, to demand assignment of the buyer's claims for return against third parties. Our taking back or seizure of the goods subject to retention of title does not constitute a withdrawal from the contract, unless the law on instalment payments applies.

X. Excess and shortfall in performance, warranty and damages

1. In the case of series orders, in particular of pressed, stamped and drawn parts, we reserve the right to over- or under-deliver by up to 10 %.

2. We are only liable for defects as follows: The buyer shall inspect the received goods immediately upon arrival for defects and warranted characteristics. Obvious defects are to be notified to us immediately in writing, hidden defects within five working days.

In the event of justified complaints, we shall, at our discretion, rectify the defective goods, make a replacement delivery or issue a credit note. The buyer shall grant us the time and opportunity reasonably required to remedy the defect; otherwise the warranty shall lapse.

If we do not provide a warranty by rectification, replacement delivery or credit note within a reasonable period of grace granted to us, the buyer shall be entitled to demand rescission of the contract or reduction of the purchase price. Warranty claims for defects shall become statute-barred 12 months after delivery. The warranty period for repairs is 3 months, for replacement deliveries and replacement services 6 months. It shall run at least until the expiry of the original warranty period for the delivery item. Claims for damages by the buyer arising from culpa in contrahendo, breach of ancillary contractual obligations and tort are excluded, unless the claims are based on intent or gross negligence. This exclusion of liability also applies to consequential damages. Claims for damages shall become statute-barred 12 months after receipt of the goods by the buyer.

XI. Taking back goods

In the event that we take back goods by offsetting them against purchase price claims, we shall issue a credit note. In the case of goods in saleable condition, 20 % of the purchase price, but at least 25 EUR, will be deducted for our expenses. In the case of damaged goods and older deliveries, we shall issue a credit note to the amount of the resale proceeds estimated by us at our reasonable discretion, deducting our above reimbursement of expenses. Custom-made products are excluded from return.

XII. Final provisions

1. Place of performance for deliveries and payments is Velbert. The local court of Velbert or the regional court of Wuppertal is agreed as the place of jurisdiction, insofar as the customer is a registered trader, a legal entity under public law or a special fund under public law.
2. The relations between the parties shall be governed exclusively by the law applicable in the Federal Republic of Germany to the exclusion of the Hague Convention on Contracts for the International Sale of Goods.
3. Should any clause of these terms and conditions of sale be invalid, this shall not affect the validity of the remaining contractual clauses.

TERMS OF USE

Rocholz GmbH accepts no liability for the up-to-dateness, accuracy or completeness of the content and information.
We reserve the right to change dimensions, weights or colours, or to alter the designs. This catalogue is protected by copyright.
Reproduction - even of extracts - is permissible only with the written consent of the publisher.
Illustrations partially show accessories and decorative materials which are not supplied. Please refer to the product description for the actual scope of delivery. Subject to price and technical changes. No liability for printing errors.
Liability claims against Rocholz GmbH relating to material or immaterial damage caused by the use or non-use of the information provided or by incorrect or incomplete information are fundamentally excluded.

Used images:
Page 4 & 5 // Hall background - istockphoto.com - RonFullHD (1253446602)
Page 5 & 16 & 33 & 52 & 76 & 84 & 96 & 126 // Background - freepik.com - rawpixel.com
Page 13 // Ants - istockphoto.com - Robi_J (1134933739)
Page 17 // Hall with packing tables - myToys.de GmbH
Page 26 // Application at the Nölle company
Page 124 // Leaf-cutting ants - istockphoto.com - Luis Castillo (1317627899)

Commercial register | District court Wuppertal, HRB 17337
Executive management | Dipl.-Ing. Marc Rocholz, Dipl.-Betriebsw. Ralph Roth
VAT ID-No. | DE 330641855



ROCHOLZ
LÖSUNGEN MIT SYSTEM

 **Rocholz GmbH** · Nevigeser Str. 240 - 242 · 42553 Velbert · Germany

 **Fon** +49 2053 819-0

 **Mail** info@rocholz.de

 **Mon-Thurs** 8:30 am - 5:00 pm
Fri 8:30 am - 2:00 pm

22-05-2024